

Series LFII Residential Concealed Pendent Sprinkler, Domed Plate 4.9 K-factor

General Description

The Series LFII (TY2234) Residential Concealed Pendent Sprinklers are decorative, fast response, frangible bulb sprinklers designed for use in residential occupancies such as homes, apartments, dormitories, and hotels.

The cover plate assembly conceals the sprinkler operating components above the ceiling. The domed profile of the cover plate provides aesthetically appealing sprinkler design with lower flow rates than can be achieved by lower profile cover plates. The separable two-piece design of the Cover Plate and Support Cup Assemblies allows installation of the sprinklers and pressure testing of the fire protection system prior to the installation of the ceiling or application of a finish coating.

Also, the separable "push-on and thread-off" two-piece design of the Sprinkler provides for 1/2 inch (12,7 mm) of vertical adjustment.

The Series LFII are to be used in wet pipe residential sprinkler systems for one- and two-family dwellings and mobile homes per NFPA 13D; wet pipe residential sprinkler systems for residential occupancies up to and including four stories in height per NFPA

IMPORTANT

Always refer to Technical Data Sheet TFP700 for the "INSTALLER WARNING" that provides cautions with respect to handling and installation of sprinkler systems and components. Improper handling and installation can permanently damage a sprinkler system or its components and cause the sprinkler to fail to operate in a fire situation or cause it to operate prematurely.

13R; or, wet pipe sprinkler systems for the residential portions of any occupancy per NFPA 13.

The Series LFII (TY2234) has a 4.9 (70,6) K-factor that provides the required residential flow rates at reduced pressures, enabling smaller pipe sizes and water supply requirements.

The Series LFII (TY2234) has been designed with heat sensitivity and water distribution characteristics proven to help in the control of residential fires and to improve the chance for occupants to escape or be evacuated.

The Series LFII (TY2234) Residential Concealed Pendent Sprinklers are shipped with a Disposable Protective Cap. The Protective Cap is temporarily removed for installation, and it must be replaced to protect the sprinkler while the ceiling is being installed or finished. The tip of the Protective Cap can also be used to mark the center of the ceiling hole into plaster board, ceiling tiles, etc. by gently pushing the ceiling product against the Protective Cap. When ceiling installation is complete, the Protective Cap must be removed and the Cover Plate Assembly installed. The Protective Cap must be removed to ensure proper performance of the sprinklers.

WARNINGS

*The Series LFII (TY2234) Residential Concealed Pendent Sprinklers described herein must be installed and maintained in compliance with this document, as well as with the applicable standards of the National Fire Protection Association, in addition to the standards of any other authorities having jurisdiction. **Failure to do so may impair the performance of these devices.***

The owner is responsible for maintaining their fire protection system and devices in proper operating condition. The installing contractor or sprinkler manufacturer should be contacted with any questions.



Sprinkler/Model Identification Number

SIN TY2234

Technical Data

Approvals:

UL and C-UL Listed.

Maximum Working Pressure:

175 psi (12,1 bar)

Discharge Coefficient:

K = 4.9 GPM/psi^{1/2} (70,6 LPM/bar^{1/2})

Temperature Rating:

155°F/68°C Sprinkler with
135°F/57°C Cover Plate

Vertical Adjustment:

1/2 inch (12,7 mm)

Finishes:

Cover Plate:
Flat White, Bright White, Chrome, or
Custom

Maximum Coverage Area ^(a) Ft. x Ft. (m x m)	Maximum Spacing Ft. (m)	Minimum Flow ^(b) and Residual Pressure For Horizontal Ceiling (Max. 2 Inch Rise for 12 inch Run)	Minimum Flow ^(b) and Residual Pressure For Sloped Ceiling (Greater Than 2 Inch Rise Up To Max. 4 Inch Rise for 12 inch Run)	Minimum Flow ^(b) and Residual Pressure For Sloped Ceiling (Greater Than 4 Inch Rise Up To Max. 8 Inch Rise for 12 inch Run)
		155°F/68°C Sprinkler	155°F/68°C Sprinkler	155°F/68°C Sprinkler
12 x 12 (3,7 x 3,7)	12 (3,7)	13 GPM (49,2 LPM) 7.0 psi (0,48 bar)	13 GPM (49,2 LPM) 7.0 psi (0,48 bar)	19 GPM (71,9 LPM) 15.0 psi (1,03 bar)
14 x 14 (4,3 x 4,3)	14 (4,3)	13 GPM (49,2 LPM) 7.0 psi (0,48 bar)	13 GPM (49,2 LPM) 7.0 psi (0,48 bar)	19 GPM (71,9 LPM) 15.0 psi (1,03 bar)
16 x 16 (4,9 x 4,9)	16 (4,9)	13 GPM (49,2 LPM) 7.0 psi (0,48 bar)	13 GPM (49,2 LPM) 7.0 psi (0,48 bar)	19 GPM (71,9 LPM) 15.0 psi (1,03 bar)
18 x 18 (5,5 x 5,5)	18 (5,5)	17 GPM (64,3 LPM) 12.0 psi (0,83 bar)	17 GPM (64,3 LPM) 12.0 psi (0,83 bar)	19 GPM (71,9 LPM) 15.0 psi (1,03 bar)
20 x 20 (6,1 x 6,1)	20 (6,1)	20 GPM (75,7 LPM) 16.7 psi (1,15 bar)	21 GPM (79,5 LPM) 18.4 psi (1,27 bar)	24 GPM (90,8 LPM) 24.0 psi (1,65 bar)

(a) For coverage area dimensions less than or between those indicated, it is necessary to use the minimum required flow for the next highest coverage area for which hydraulic design criteria are stated.

(b) Requirement is based on minimum flow in GPM (LPM) from each sprinkler. The associated residual pressures are calculated using the nominal K-factor. Refer to Hydraulic Design Criteria Section for details.

**TABLE A
NFPA 13D AND NFPA 13R WET PIPE HYDRAULIC DESIGN CRITERIA
FOR THE SERIES LFII (TY2234)
RESIDENTIAL CONCEALED PENDENT SPRINKLER**

Physical Characteristics:

- Frame Brass
- Button Bronze
- Sealing Assembly Beryllium Nickel w/ Teflon*
- Bulb 3 mm dia. Glass
- Compression Screw Brass
- Deflector Copper
- Button Ejection Spring Stainless Steel
- Support Cup Steel
- Cover Plate Brass
- Retainer Brass
- Cover Plate Ejection Spring Stainless Steel

*DuPont Registered Trademark

Operation

When exposed to heat from a fire, the Cover Plate, which is normally soldered to the Support Cup at three points, falls away to expose the Sprinkler Assembly. The glass bulb contains a fluid that expands when exposed to heat. When the rated temperature is reached, the fluid expands sufficiently to shatter the glass bulb allowing the sprinkler to activate and flow water.

Design Criteria

The Series LFII (TY2234) Residential Concealed Pendent Sprinklers are UL and C-UL Listed for installation in accordance with the following criteria.

NOTE

When conditions exist that are outside the scope of the provided criteria, refer to the Residential Sprinkler Design Guide TFP490 for the manufacturer's recommendations that may be acceptable to the Authority Having Jurisdiction.

System Type. Only wet pipe systems may be utilized.

Hydraulic Design. The minimum required sprinkler flow rate for systems designed to NFPA 13D or NFPA 13R are given in Table A as a function of temperature rating and the maximum allowable coverage areas. The sprinkler flow rate is the minimum required discharge from each of the total number of "design sprinklers" as specified in NFPA 13D or NFPA 13R.

For systems designed to NFPA 13, the number of design sprinklers is to be the four most hydraulically demanding sprinklers. The minimum required dis-

charge from each of the four sprinklers is to be the greater of the following:

- The flow rates given in Table A for NFPA 13D and 13R as a function of temperature rating and the maximum allowable coverage area.
- A minimum discharge of 0.1 gpm/sq. ft. over the "design area" comprised of the four most hydraulically demanding sprinklers for the actual coverage areas being protected by the four sprinklers.

Obstruction To Water Distribution. Locations of sprinklers are to be in accordance with the obstruction rules of NFPA 13 for residential sprinklers.

Operational Sensitivity. The sprinklers are to be installed relative to the ceiling mounting surface as shown in Figure 2.

Sprinkler Spacing. The minimum spacing between sprinklers is 8 feet (2,4 m). The maximum spacing between sprinklers cannot exceed the length of the coverage area (Ref. Table A) being hydraulically calculated (e.g., maximum 12 feet for a 12 ft. x 12 ft. coverage area, or 20 feet for a 20 ft. x 20 ft. coverage area).

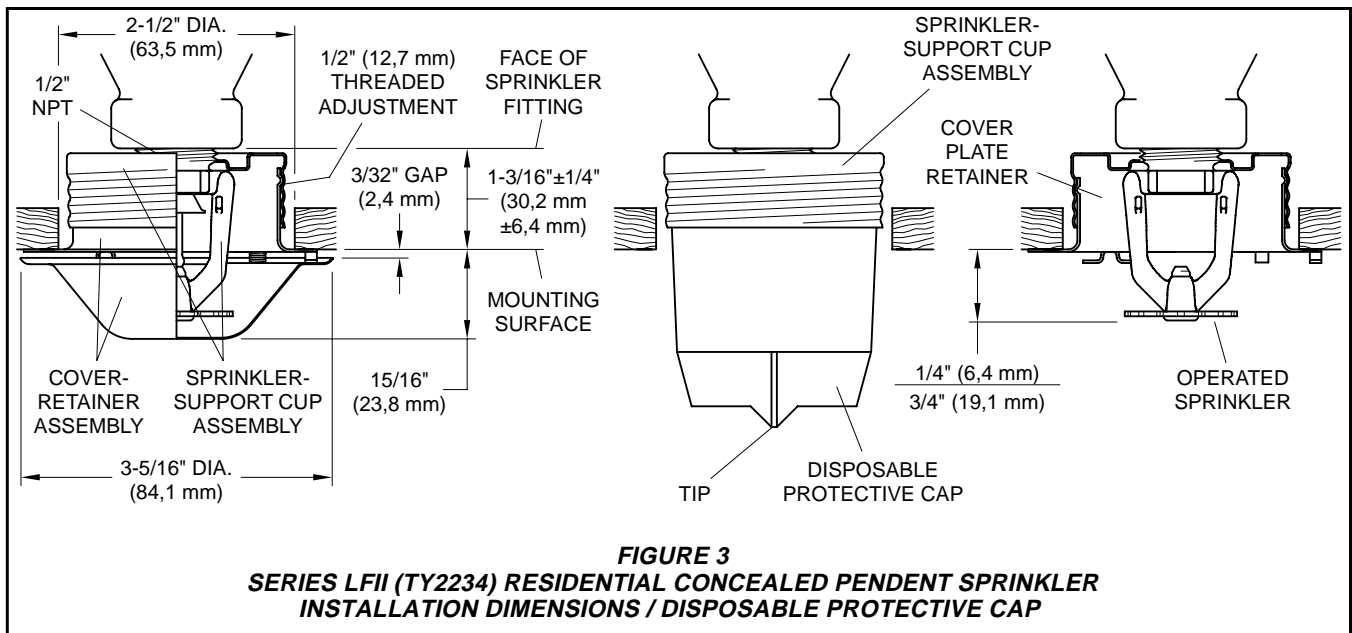
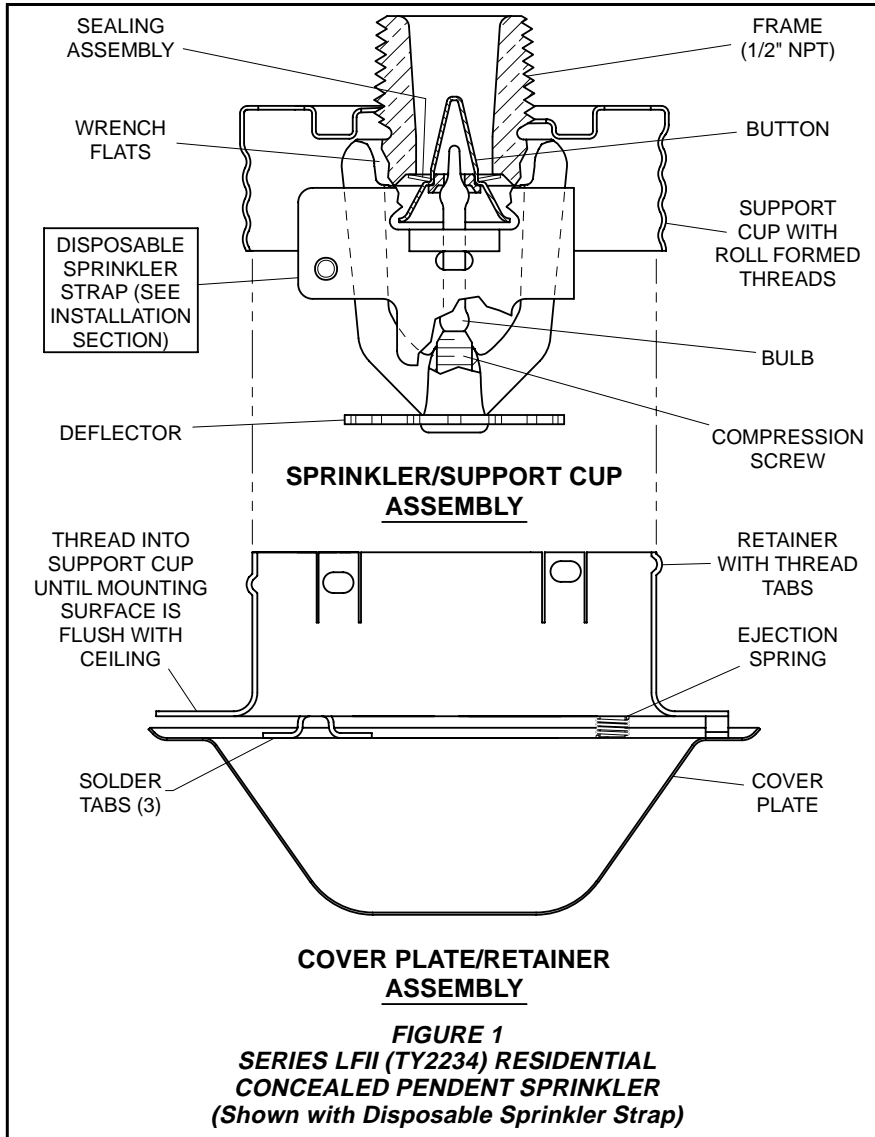

Installation

The Series LFII (TY2234) must be installed in accordance with the following instructions:

NOTES

Do not install any bulb type sprinkler if the bulb is cracked or there is a loss of liquid from the bulb. With the sprinkler held horizontally, a small air bubble should be present. The diameter of the air bubble is approximately 1/16 inch (1,6 mm).

A leak tight 1/2 inch NPT sprinkler joint should be obtained with a torque of 7 to 14 ft.lbs. (9,5 to 19,0 Nm). A maximum of 21 ft.lbs. (28,5 Nm) of torque is to be used to install sprinklers. Higher levels of torque may distort the sprinkler inlet with consequent leakage or impairment of the sprinkler.

Do not attempt to compensate for insufficient adjustment in an Escutcheon Plate by under- or over-tightening the Sprinkler. Readjust the position of the sprinkler fitting to suit.

Step 1. The sprinkler must only be installed in the pendent position and with the centerline of the sprinkler perpendicular to the mounting surface.

Step 2. Remove the Protective Cap.

NOTE

Do not remove the Sprinkler Strap (Fig. 1) until the sprinkler system is to be placed in service.

Step 3. With pipe thread sealant applied to the pipe threads, and using the W-Type 7 Wrench shown in Figure 2, install and tighten the Sprinkler/Support Cup Assembly into the fitting. The W-Type 7 Wrench will accept a 1/2 inch ratchet drive.

Step 4. Replace the Protective Cap by pushing it upwards until it bottoms out against the Support Cup. The Protective Cap helps prevent damage to the Deflector and Arms during ceiling installation and/or during application of the finish coating of the ceiling. It may also be used to locate the center of the clearance hole by gently pushing the ceiling material against the center point of the Cap.

NOTE

As long as the Sprinkler Strap (Fig. 1) or the Protective Cap (Fig. 3) remains in place, the system is considered to be "Out Of Service".

Step 5. After the ceiling has been completed with the 2-1/2 inch (63 mm) diameter clearance hole and in preparation for installing the Cover Plate/Retainer Assembly, remove and discard

the Protective Cap and the Sprinkler Strap.

NOTE

Refer to Technical Data Sheet TFP700 regarding instructions for the removal of the Sprinkler Strap.

Step 6. Push the Cover Plate/Retainer Assembly into the Support Cup, and as necessary, make the final adjustment of the Cover Plate with respect to the ceiling by turning the Cover Plate/Retainer Assembly clockwise until its flange just comes in contact with the ceiling.

If it becomes necessary to remove the Cover Plate, it can be removed by unscrewing in a counter-clockwise direction.

If the Cover Plate/Retainer Assembly cannot be engaged with the Support Cup or the Cover Plate/Retainer Assembly cannot be engaged sufficiently to contact the ceiling, the Sprinkler Fitting must be repositioned.

Care and Maintenance

The Series LFII (TY2234) must be maintained and serviced in accordance with the following instructions:

NOTES

Absence of an Escutcheon Plate may delay the sprinkler operation in a fire situation.

Before closing a fire protection system main control valve for maintenance work on the fire protection system which it controls, permission to shut down the affected fire protection system must be obtained from the proper authorities and all personnel who may be affected by this action must be notified.

Sprinklers which are found to be leaking or exhibiting visible signs of corrosion must be replaced.

Automatic sprinklers must never be painted, plated, coated, or otherwise altered after leaving the factory. Modified or over heated sprinklers must be replaced.

Care must be exercised to avoid damage - before, during, and after installation. Sprinklers damaged by dropping, striking, wrench twist/slippage, or the like, must be replaced.

The owner is responsible for the inspection, testing, and maintenance of their fire protection system and devices in compliance with this document, as well as with the applicable standards of the National Fire Protection Association (e.g., NFPA 25), in addition to the standards of any other authorities having jurisdiction. The installing contractor or sprinkler manufacturer should be contacted relative to any questions.

NOTE

The owner must assure that the sprinklers are not used for hanging of any objects and that the sprinklers are only cleaned by means of gently dusting with a feather duster; otherwise, non-operation in the event of a fire or inadvertent operation may result.

It is recommended that automatic sprinkler systems be inspected, tested, and maintained by a qualified Inspection Service in accordance with local requirements and/or national codes.

Limited Warranty

Products manufactured by Tyco Fire & Building Products (TFBP) are warranted solely to the original Buyer for ten (10) years against defects in material and workmanship when paid for and properly installed and maintained under normal use and service. This warranty will expire ten (10) years from date of shipment by TFBP. No warranty is given for products or components manufactured by companies not affiliated by ownership with TFBP or for products and components which have been subject to misuse, improper installation, corrosion, or which have not been installed, maintained, modified or repaired in accordance with applicable Standards of the National Fire Protection Association, and/or the standards of any other Authorities Having Jurisdiction. Materials found by TFBP to be defective shall be either repaired or replaced, at TFBP's sole option. TFBP neither assumes, nor authorizes any person to assume for it, any other obligation in connection with the sale of products or parts of products. TFBP shall not be responsible for sprinkler system design errors or inaccurate or incomplete information supplied by Buyer or Buyer's representatives.

In no event shall TFBP be liable, in contract, tort, strict liability or under any other legal theory, for incidental, indirect, special or consequential damages, including but not limited to labor charges, regardless of whether TFBP was informed about the possibility of such damages, and in no event shall TFBP's liability exceed an amount equal to the sales price.

The foregoing warranty is made in lieu of any and all other warranties, express or implied, including warranties of merchantability and fitness for a particular purpose.

This limited warranty sets forth the exclusive remedy for claims based on failure of or defect in products, materials or components, whether the claim is made in contract, tort, strict liability or any other legal theory.

This warranty will apply to the full extent permitted by law. The invalidity, in whole or part, of any portion of this warranty will not affect the remainder.

Ordering Procedure

When placing an order, indicate the full product name. Contact your local distributor for availability.

Sprinkler Assembly:

Series LFII (TY2234), K=4.9, Residential Concealed Pendent Sprinkler without Cover Plate Assembly, P/N 51-873-1-155.

Cover Plate Assembly:

Cover Plate Assembly having a (specify) finish for the Series LFII (TY2234), K=4.9, Residential Concealed Pendent Sprinkler, P/N (specify).

Chrome	P/N 56-873-9-135
Off White	P/N 56-873-0-135
Bright White	P/N 56-873-4-135
Flat White	P/N 56-873-5-135
White (RAL 9010)*	P/N 56-873-3-135
Custom	P/N 56-873-X-135

*Eastern Hemisphere sales only.

Sprinkler Wrench:

Specify: W-Type 7 Sprinkler Wrench, P/N 56-850-4-001.

