

Model ESFR-17 **Early Suppression Fast Response Pendent Sprinklers** **16.8 K-factor**

General Description

The Model ESFR-17 Pendent Sprinklers (Ref. Figure 1) are "Early Suppression Fast Response Sprinklers" having a nominal K-factor of 16.8. They are suppression mode sprinklers that are especially advantageous as a means of eliminating in-rack sprinklers, when protecting rack storage.

The Model ESFR-17 is primarily designed for use in ceiling only sprinkler systems (i.e. no in-rack sprinklers) for the protection of storage heights of most encapsulated or non-encapsulated common materials including cartoned unexpanded plastics of up to 35 ft. (10,7 m) with ceiling heights to 40 ft. (12,2 m), as well as cartoned expanded plastics up to 25 ft. (7,6 m) with ceiling heights to 30 ft. (9,1 m). In addition, the protection of some storage arrangements of rubber tires, roll paper, and aerosols can be considered.

In some cases, the Model ESFR-17 can be used to protect storage heights up to 40 ft. (12,2 m) with ceiling heights to 45 ft. (13,7 m) in combination with one level of in-rack sprinklers.

The ESFR-17 provides the system designer with hydraulic options not presently available to traditional ESFR sprinklers having a nominal K-Factor

of 14.0. In particular, the Model ESFR-17 has been designed to operate at substantially lower end head pressures, as compared to ESFR sprinklers having a nominal K-Factor of 14.0. This feature offers flexibility when sizing the system piping, as well as possibly reducing or eliminating the need for a system fire pump.

WARNINGS

*The Model ESFR-17 Sprinklers described herein must be installed and maintained in compliance with this document, as well as with the applicable standards of the National Fire Protection Association, in addition to the standards of any other authorities having jurisdiction (e.g., FM Global). **Failure to do so may impair the performance of these devices.***

The owner is responsible for maintaining their fire protection system and devices in proper operating condition. The installing contractor or sprinkler manufacturer should be contacted with any questions.



Sprinkler Identification Numbers

SIN TY7226 - (Pendent K=16.8)

IMPORTANT

Always refer to Technical Data Sheet TFP700 for the "INSTALLER WARNING" that provides cautions with respect to handling and installation of sprinkler systems and components. Improper handling and installation can permanently damage a sprinkler system or its components and cause the sprinkler to fail to operate in a fire situation or cause it to operate prematurely.

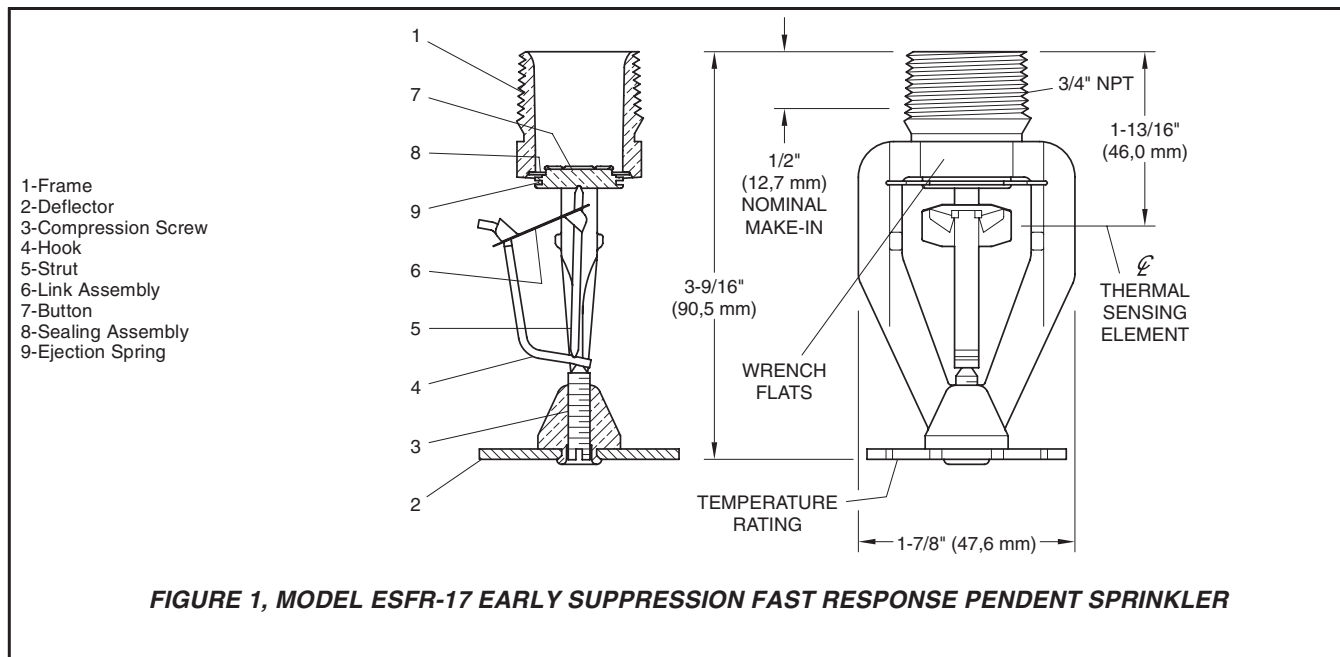

FIGURE 1, MODEL ESFR-17 EARLY SUPPRESSION FAST RESPONSE PENDENT SPRINKLER

Technical Data

Approvals

UL and C-UL Listed. FM and VdS Approved. LPCB Approved (094b/01 & 0071/01). NYC under MEA 356-01-E.

Maximum Working Pressure

175 psi (12,1 bar)

Pipe Thread Connection

3/4 inch NPT or ISO 7-R3/4

Discharge Coefficient

$K = 16.8 \text{ GPM/psi}^{1/2}$
(241,9 LPM/bar^{1/2})

Temperature Ratings

165°F/74°C or 214°F/101°C

Finish

Natural Brass

Physical Characteristics

Frame	Brass
Deflector	Bronze
Compression Screw	Stainless Steel
Hook	Monel
Strut	Monel
Link Assembly	Solder, Nickel
Button	Brass
Sealing Assembly	Beryllium Nickel w/Teflon*
Ejection Spring	Inconel

*Registered trademark of Dupont.

Patents

U.S.A. Patent Numbers:
4,580,729 5,829,532
6,059,044 6,336,509
6,502,643
Patents pending.

Design Criteria

NOTE

The National Fire Protection Association (NFPA) and FM Global (FM) provide installation standards that must be used to properly design an automatic sprinkler system utilizing Early Suppression Fast Response (ESFR) Sprinklers. The guidelines provided by NFPA and FM may differ; consequently, the appropriate standard must be used for a given installation.

The following data sheets describe the ESFR Sprinklers offered by Tyco Fire Products:

TFP312 — Model ESFR-25 (TY9226), K=25.2 Pendent Sprinkler

TFP315 — Model ESFR-17 (TY7226), K=16.8 Pendent Sprinkler

TFP316 — Model ESFR-17 (TY7126), K=16.8 Upright Sprinkler

TFP318 — Model ESFR-1 (TY6226), K=14.0 Pendent Sprinkler

The following general guidelines provided for ESFR Sprinklers offered by Tyco Fire Products may be used for a quick reference to help select the appropriate Tyco Fire Products' ESFR Sprinkler:

NOTE

In all cases, the appropriate NFPA or FM installation standard must be referenced to assure applicability and to obtain complete installation guidelines, since the following general

guidelines are not intended to provide complete installation criteria.

GENERAL GUIDELINES

System Type: Wet pipe system.

Roof Construction: Unobstructed or obstructed construction. For example: smooth ceiling, bar joists, beam and girder, etc.

NOTE

Where the depths of the solid structural members (beams, stem, etc.) exceed 12 inches (302 mm), ESFR Sprinklers shall be installed in each channel formed by the structural members.

Ceiling Slope: Maximum 2 inch rise for 12 inch run (16.7%).

Building Heights, Storage Heights, and Commodity: Refer to Table A.

Maximum Coverage Area: 100 ft² (9,3 m²). In some cases, the installation standards permit a greater coverage area.

Minimum Coverage Area: 80 ft² (7,4 m²) per NFPA 13, and 64 ft² (5,8 m²) per FM 2-2

Maximum Spacing: 12 feet (3,7 m) for building heights up to 30 feet (9,1 m), and 10 feet (3,1 m) for building heights greater than 30 feet (9,1 m).

Minimum Spacing: 8 feet (2,4 m).

Minimum Clearance To Commodity: 36 inches (914 mm).

**TABLE A
BUILDING HEIGHTS, STORAGE HEIGHTS, AND COMMODITY
(See Design Criteria Section)**

Open frame (i.e. no solid shelves) single, double, multiple-row, or portable rack storage of Class I - IV and Group A or B plastics	See Table A-1 (Refer to NFPA 13 or FM 8-9 and 2-2 for details)							
Solid pile or palletized storage of Class I - IV and Group A or B plastics	See Table A-2 (Refer to NFPA 13 or FM 8-9 and 2-2 for details)							
Idle pallet storage	See Table A-3 (Refer to NFPA 13 or FM 8-24 and 2-2 for details)							
Rubber Tire Storage	See Table A-4 (Refer to NFPA 13 or FM 8-3 and 2-2 for details)							
	ESFR-17 PENDENT K = 16.8		Comparison to Other TFP ESFR Sprinklers					
			ESFR-1 PENDENT K = 14.0 See Data Sheet TFP318		ESFR-17 UPRIGHT K = 16.8 See Data Sheet TFP316		ESFR-25 PENDENT K = 25.2 See Data Sheet TFP312	
	NFPA	FM	NFPA	FM	NFPA	FM	NFPA	FM
Rolled Paper Storage (See Standard)	13	—	13	8-21	—	8-21	13	8-21
Flammable Liquid Storage (See Standard)	—	—	30	7-29	—	—	30	—
Aerosol Storage (See Standard)	30B	—	30B	7-31	—	—	30B	7-31
Automotive Components in Portable Racks (Control Mode Only, See Standard)	—	—	—	—	—	—	13	—

NFPA 13 — Deflector To Ceiling Distance:

ESFR-17 (K=16.8) Pendent:
6 to 14 inches (152 to 356 mm).
ESFR-1 (K=14.0) Pendent:
6 to 14 inches (152 to 356 mm).
ESFR-25 (K=25.2) Pendent:
6 to 18 inches (152 to 457 mm).

FM 2-2 — Deflector To Ceiling Distance:

ESFR-17 (K=16.8) Pendent:
5 to 14 inches (121 to 356 mm).
ESFR-1 (K=14.0) Pendent:
5 to 14 inches (121 to 356 mm).
ESFR-17 (K=16.8) Upright:
5 to 14 inches (121 to 356 mm).

FM 2-2 — Thermal Sensing Element To Ceiling Distance:

ESFR-17 (K=16.8) Pendent:
4 to 13 inches (102 to 330 mm).
ESFR-1 (K=14.0) Pendent:
4 to 13 inches (102 to 330 mm).
ESFR-17 (K=16.8) Upright:
4 to 13 inches (102 to 330 mm).
ESFR-25 (K=25.2) Pendent:
4 to 18 inches (102 to 457 mm).

**TABLE A-1
RACK STORAGE
(See Design Criteria Section)**

Commodity	Maximum Building Height, Feet (m)	Maximum Storage Height, Feet (m)	Minimum Flow Pressure, PSI (BAR)								
			ESFR-17 PENDENT K = 16.8	Comparison to Other TFP ESFR Sprinklers							
				ESFR-1 PENDENT K = 14.0 See Data Sheet TFP318		ESFR-17 UPRIGHT K = 16.8 See Data Sheet TFP316		ESFR-25 PENDENT K = 25.2 See Data Sheet TFP312			
				NFPA	FM	NFPA	FM	NFPA	FM	NFPA	FM
Class I, Class II, Class III, and Class IV Encapsulated or Unencapsulated -and- Cartoned Unexpanded Plastics	45 (13,7)	40 (12,2)	63* (4,3)	63* (4,3)	90* (6,2)	90* (6,2)	-	-	40 (2,8)	50 (3,4)	
	40 (12,2)	35 (10,7)	52 (3,6)	52 (3,6)	75 (5,2)	75 (5,2)	-	-	25 (1,7)	40 (2,8)	
	35 (10,7)	30 (9,1)	52 (3,6)	52 (3,6)	75 (5,2)	75 (5,2)	-	52 (3,6)	20 (1,4)	30 (2,1)	
	32 (9,7)	25 (7,6)	42 (2,9)	42 (2,9)	60 (4,1)	60 (4,1)	-	42 (2,9)	20 (1,4)	30 (2,1)	
	30 (9,1)	25 (7,6)	35 (2,4)	35 (2,4)	50 (3,4)	50 (3,4)	-	35 (2,4)	15 (1,0)	20 (1,4)	
Uncartoned (Exposed) Unexpanded Plastics	45 (13,7)	40 (12,2)	63* (4,3)	63* (4,3)	90* (6,2)	90* (6,2)	-	-	-	-	
	40 (12,2)	35 (10,7)	52 (3,6)	52 (3,6)	75 (5,2)	75 (5,2)	-	-	-	50 (3,4)	
	32 (9,7)	25 (7,6)	42 (2,9)	42 (2,9)	60 (4,1)	60 (4,1)	-	-	-	50 (3,4)	
	30 (9,1)	25 (7,6)	35 (2,4)	35 (2,4)	50 (3,4)	50 (3,4)	-	-	-	50 (3,4)	
Cartoned Expanded Plastics	32 (9,7)	25 (7,6)	42 (2,9)	42 (2,9)	60 (4,1)	60 (4,1)	-	42 (2,9)	-	-	
	30 (9,1)	25 (7,6)	35 (2,4)	35 (2,4)	50 (3,4)	50 (3,4)	-	35 (2,4)	-	-	
Uncartoned (Exposed) Expanded Plastics	30 (9,1)	25 (7,6)	-	-	-	100 (6,8)	-	-	-	-	
	25 (7,6)	20 (6,1)	-	-	-	75 (5,2)	-	-	-	-	

* One level of in-rack sprinklers is required.

**TABLE A-2
PALLETIZED AND SOLID PILED STORAGE
(See Design Criteria Section)**

Commodity	Maximum Building Height, Feet (m)	Maximum Storage Height, Feet (m)	Minimum Flow Pressure, PSI (BAR)							
			ESFR-17 PENDENT K = 16.8		Comparison to Other TFP ESFR Sprinklers					
					ESFR-1 PENDENT K = 14.0 See Data Sheet TFP318		ESFR-17 UPRIGHT K = 16.8 See Data Sheet TFP316		ESFR-25 PENDENT K = 25.2 See Data Sheet TFP312	
					NFPA	FM	NFPA	FM	NFPA	FM
Class I, Class II, Class III, and Class IV Encapsulated or Unencapsulated -and- Cartoned Unexpanded Plastics	45 (13,7)	40 (12,2)	-	-	-	-	-	-	40 (2,8)	50 (3,4)
	45 (13,7)	35 (10,7)	-	-	-	90 (6,2)	-	-	40 (2,8)	50 (3,4)
	40 (12,2)	35 (10,7)	52 (3,6)	52 (3,6)	75 (5,2)	75 (5,2)	-	-	25 (1,7)	40 (2,8)
	35 (10,7)	30 (9,1)	52 (3,6)	52 (3,6)	75 (5,2)	75 (5,2)	-	52 (3,6)	20 (1,4)	30 (2,1)
	32 (9,7)	25 (7,6)	42 (2,9)	42 (2,9)	60 (4,1)	60 (4,1)	-	42 (2,9)	20 (1,4)	30 (2,1)
	30 (9,1)	25 (7,6)	35 (2,4)	35 (2,4)	50 (3,4)	50 (3,4)	-	35 (2,4)	15 (1,0)	20 (1,4)
Uncartoned (Exposed) Unexpanded Plastics	45 (13,7)	35 (10,7)	-	-	-	90 (6,2)	-	-	-	-
	40 (12,2)	35 (10,7)	52 (3,6)	52 (3,6)	75 (5,2)	75 (5,2)	-	-	-	50 (3,4)
	32 (9,7)	25 (7,6)	42 (2,9)	42 (2,9)	60 (4,1)	60 (4,1)	-	-	-	50 (3,4)
	30 (9,1)	25 (7,6)	35 (2,4)	35 (2,4)	50 (3,4)	50 (3,4)	-	-	-	50 (3,4)
Cartoned Expanded Plastics	32 (9,7)	25 (7,6)	42 (2,9)	42 (2,9)	60 (4,1)	60 (4,1)	-	42 (2,9)	-	-
	30 (9,1)	25 (7,6)	35 (2,4)	35 (2,4)	50 (3,4)	50 (3,4)	-	35 (2,4)	-	-
Uncartoned (Exposed) Expanded Plastics	40 (12,2)	25 (7,6)	-	-	-	-	-	-	-	60 (4,1)
	30 (9,1)	25 (7,6)	-	-	-	100 (6,8)	-	-	-	60 (4,1)
	25 (7,6)	20 (6,1)	-	-	-	75 (5,2)	-	-	-	60 (4,1)

**TABLE A-3
IDLE PALLET STORAGE
(See Design Criteria Section)**

Type and Arrangement	Maximum Building Height, Feet (m)	Maximum Storage Height, Feet (m)	Minimum Flow Pressure, PSI (BAR)							
			ESFR-17 PENDENT K = 16.8		Comparison to Other TFP ESFR Sprinklers					
					ESFR-1 PENDENT K = 14.0 See Data Sheet TFP318		ESFR-17 UPRIGHT K = 16.8 See Data Sheet TFP316		ESFR-25 PENDENT K = 25.2 See Data Sheet TFP312	
					NFPA	FM	NFPA	FM	NFPA	FM
Wood or Plastic In-rack -and- Plastic on Floor	40 (12,2)	35 (10,7)	52 (3,6)	52 (3,6)	75 (5,2)	75 (5,2)	-	-	-	50 (3,4)
	32 (9,7)	25 (7,6)	42 (2,9)	42 (2,9)	60 (4,1)	60 (4,1)	-	-	-	50 (3,4)
	30 (9,1)	25 (7,6)	35 (2,4)	35 (2,4)	50 (3,4)	50 (3,4)	-	-	-	50 (3,4)
Wood on Floor	40 (12,2)	35 (10,7)	52 (3,6)	52 (3,6)	75 (5,2)	75 (5,2)	-	-	-	50 (3,4)
	35 (10,7)	20 (6,1)	52 (3,6)	52 (3,6)	75 (5,2)	75 (5,2)	-	52 (3,6)	-	50 (3,4)
	32 (9,7)	25 (7,6)	42 (2,9)	42 (2,9)	60 (4,1)	60 (4,1)	-	-	-	50 (3,4)
	32 (9,7)	20 (6,1)	42 (2,9)	42 (2,9)	60 (4,1)	60 (4,1)	-	42 (2,9)	-	50 (3,4)
	30 (9,1)	25 (7,6)	35 (2,4)	35 (2,4)	50 (3,4)	50 (3,4)	-	-	-	50 (3,4)
	30 (9,1)	20 (6,1)	35 (2,4)	35 (2,4)	50 (3,4)	50 (3,4)	-	35 (2,4)	-	50 (3,4)

**TABLE A-4
RUBBER TIRE STORAGE
(See Design Criteria Section)**

Piling Method	Maximum Building Height, Feet (m)	Maximum Storage Height, Feet (m)	Minimum Flow Pressure, PSI (BAR)							
			Comparison to Other TFP ESFR Sprinklers							
			ESFR-17 PENDENT K = 16.8		ESFR-1 PENDENT K = 14.0 See Data Sheet TFP318		ESFR-17 UPRIGHT K = 16.8 See Data Sheet TFP316		ESFR-25 PENDENT K = 25.2 See Data Sheet TFP312	
			NFPA *	FM	NFPA	FM	NFPA	FM	NFPA	FM
On-Side or On-Tread in Palletized Portable Racks, Open Portable Racks, or Fixed Racks without Solid Shelves	30 (9,1)	25 (7,6)	35 (2,4)	35 (2,4)	50 (3,5)	50 (3,5)	—	35 (2,4)	15 (1,0)	20 (1,4)
On-Side in Palletized Portable Racks, Open Portable Racks, or Fixed Racks without Solid Shelves	35 (10,7)	25 (7,6)	52 (3,6)	—	75 (5,2)	—	—	—	25 (1,7)	—
Laced Tires in Open Portable Steel Racks	30 (9,1)	25 (7,6)	52 (3,6)	—	75 (5,2)	—	—	—	—	—
On-Side in Palletized Portable Racks	40 (12,2)	25 (7,6)	52 (3,6)	—	75 (5,2)	—	—	—	—	—

* UL Listed as an equivalency to K14 ESFR protection

Operation

The fusible link assembly is comprised of two link halves that are joined together by a thin layer of solder. When the rated temperature is reached, the solder melts and the two link halves separate activating the sprinkler and allowing water to flow.

Installation

The Model ESFR-17 Pendent Sprinklers are to be installed in accordance with the following instructions:

NOTE

Damage to the fusible Link Assembly during installation can be avoided by handling the sprinkler by the frame arms only (i.e., do not apply pressure to the fusible Link Assembly), and by using the appropriate sprinkler wrench. Damaged sprinklers must be replaced.

A leak tight 3/4 inch NPT sprinkler joint should be obtained with a torque of 10

to 20 ft.lbs. (13,4 to 26,8 Nm). Higher levels of torque may distort the sprinkler inlet with consequent leakage or impairment of the sprinkler.

Step 1. The ESFR-17 Pendent Sprinkler must be installed in the pendent position.

Step 2. With pipe thread sealant applied, hand tighten the sprinkler into the sprinkler fitting. Do not apply pressure to the Link Assembly, and handle the ESFR-17 Sprinkler only by the Frame arms.

Step 3. Wrench tighten the ESFR-17 Sprinkler using only the W-Type 21 Sprinkler Wrench (Ref. Figure 2) and by fully engaging (seating) the wrench on the sprinkler wrench flats.

Step 4. After installation, inspect the Link Assembly of each ESFR-17 Sprinkler for damage. In particular, verify that the Link Assembly and Hook are positioned as illustrated in Figure 1, and that the Link Assembly has not been bent, creased, or forced out of its normal position in any way.

Damaged sprinklers must be replaced.

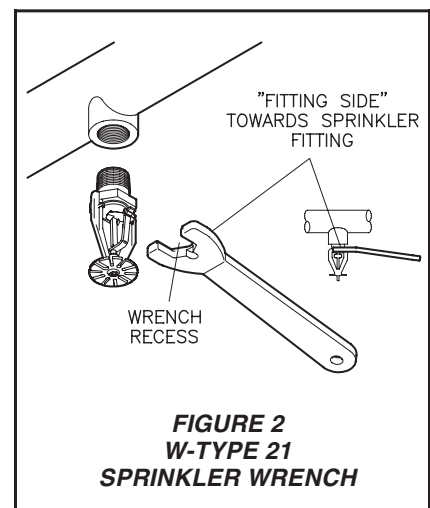

Care and Maintenance

The Model ESFR-17 must be maintained and serviced in accordance with the following instructions:

NOTE

Before closing a fire protection system main control valve for maintenance work on the fire protection system that it controls, permission to shut down the affected fire protection systems must be obtained from the proper authorities and all personnel who may be affected by this action must be notified.

Sprinklers that are found to be leaking or exhibiting visible signs of corrosion must be replaced.

Automatic sprinklers must never be painted, plated, coated, or otherwise altered after leaving the factory. Modified or over-heated sprinklers must be replaced.

Care must be exercised to avoid damage - before, during, and after installation. Sprinklers damaged by dropping, striking, wrench twist/slippage, or the like, must be replaced.

The owner is responsible for the inspection, testing, and maintenance of their fire protection system and devices in compliance with this document, as well as with the applicable standards of the National Fire Protection Association (e.g., NFPA 25), in addition to the standards of any other authorities having jurisdiction. The installing contractor or sprinkler manufacturer should be contacted relative to any questions.

It is recommended that automatic sprinkler systems be inspected, tested, and maintained by a qualified Inspection Service in accordance with local requirements and/or national code.

Limited Warranty

Products manufactured by Tyco Fire Products are warranted solely to the original Buyer for ten (10) years against defects in material and workmanship when paid for and properly installed and maintained under normal use and service. This warranty will expire ten (10) years from date of shipment by Tyco Fire Products. No warranty is given for products or components manufactured by companies not affiliated by ownership with Tyco Fire Products or for products and components which have been subject to misuse, improper installation, corrosion, or which have not been installed, maintained, modified or repaired in accordance with applicable Standards of the National Fire Protection Association, and/or the standards of any other Authorities Having Jurisdiction. Materials found by Tyco Fire Products to be defective shall be either repaired or replaced, at Tyco Fire Products' sole option. Tyco Fire Products neither assumes, nor authorizes any person to assume for it, any other obligation in connection with the sale of products or parts of products. Tyco Fire Products shall not be responsible for sprinkler system design errors or inaccurate or incomplete information supplied by Buyer or Buyer's representatives.

IN NO EVENT SHALL TYCO FIRE PRODUCTS BE LIABLE, IN CONTRACT, TORT, STRICT LIABILITY OR UNDER ANY OTHER LEGAL THEORY, FOR INCIDENTAL, INDIRECT, SPECIAL OR CONSEQUENTIAL DAMAGES, INCLUDING BUT NOT LIMITED TO LABOR CHARGES, REGARDLESS OF WHETHER TYCO FIRE PRODUCTS WAS INFORMED ABOUT THE POSSIBILITY OF SUCH DAMAGES, AND IN NO EVENT SHALL TYCO FIRE PRODUCTS' LIABILITY EXCEED AN AMOUNT EQUAL TO THE SALES PRICE.

THE FOREGOING WARRANTY IS MADE IN LIEU OF ANY AND ALL OTHER WARRANTIES EXPRESS OR IMPLIED, INCLUDING WARRANTIES OF MERCHANTABILITY AND FITNESS FOR A PARTICULAR PURPOSE.

Ordering Procedure

When placing an order, indicate the full product name. Please specify the Sprinkler Identification Number (SIN), quantity, and temperature rating. Refer to the Price List for complete listing of Part Numbers.

Contact your local distributor for availability.

Sprinkler Assemblies with NPT Thread Connections:

Specify: (specify temperature rating), natural brass, TY7226 Pendent Sprinkler, PSN (specify).

165°F/74°C P/N 58-445-1-165
214°F/101°C P/N 58-445-1-214

Sprinkler Wrench

Specify: W-Type 21 Sprinkler Wrench, P/N 56-001-0-686.