

Model DV-5 Deluge Valve, Diaphragm Style, 1-1/2 thru 8 Inch (DN40 thru DN200), 250 psi (17,2 bar) Vertical or Horizontal Installation

General Description

The 1-1/2 thru 8 inch (DN40 thru DN200), Model DV-5 Deluge Valves are diaphragm type valves designed for vertical or horizontal installation and for fire protection system service. They are used as "automatic water control valves" in deluge, preaction, and special types of fire protection systems such as foam-water and double interlock systems. When properly trimmed, the DV-5 Valves are also able to provide actuation of fire alarms upon system operation.

The diaphragm style design of the DV-5 Valve allows external resetting — providing for easy resetting of a deluge or preaction system without having to open a valve handhole cover to manually reposition a clapper and/or latch mechanism. Simply re-pressurizing the diaphragm chamber resets the valve.

The one-piece, diaphragm style design of the DV-5 also allows internal and external coating of the valve to provide corrosion resistance. The internal corrosion resistance offered by the Rilsan coating makes the DV-5 suitable for most seawater and brackish water supplies when utilized in deluge systems. The external corrosion resistance of the Rilsan coating permits the use of the DV-5 in corrosive atmospheres associated with many types of industrial processing plants and outdoor installations.

WARNING

The Model DV-5 Deluge Valves described herein must be installed and maintained in compliance with this document, as well as with the applicable standards of the National Fire Protection Association, in addition to the standards of any other authorities having jurisdiction. Failure to do so may impair the performance of these devices.



End Connections Available and Weights

End Connection		Nominal Valve Size					
Inlet	Outlet	1-1/2 Inch (DN40)	2 Inch (DN50)	3 Inch (DN80)	4 Inch (DN100)	6 Inch (DN150)	8 Inch (DN200)
Thread	Thread	9 lbs. (4,1 Kg)	12 lbs. (5,4 Kg)	N/A	N/A	N/A	N/A
Groove	Groove*	8 lbs. (3,6 Kg)	10 lbs. (4,5 Kg)	31 lbs. (14,1 Kg)	61 lbs. (27,7 Kg)	99 lbs. (44,9 Kg)	150 lbs. (68,1 Kg)
Flange	Groove*	N/A	N/A	39 lbs. (17,7 Kg)	74 lbs. (33,6 Kg)	107 lbs. (48,5 Kg)	170 lbs. (77,8 Kg)
Flange	Flange	N/A	N/A	47 lbs. (21,3 Kg)	80 lbs. (36,3 Kg)	115 lbs. (52,3 Kg)	190 lbs. (87,5 Kg)

* The Grooved Outlet is recommended for use in Preaction Systems to accommodate the use of a Groove x Groove Riser Check Valve. Refer to Technical Data Sheet TFP1410, TFP1415, TFP1420, TFP1460, or TFP1465 as applicable.

The owner is responsible for maintaining their fire protection system and devices in proper operating condition.

The installing contractor or manufacturer should be contacted with any questions.

VALVE PARTS				REPLACEMENT PARTS		
NO.	DESCRIPTION	QTY.	Refer to Kit	NO.	DESCRIPTION	P/N
1	Valve Body	1	NR	(a)	Handhole Cover Parts Kit, Includes Items 3-5	
2	Diaphragm	1	(b)		1-1/2 Inch Valve	92-477-1-106
3	Handhole Cover	1	(a)		2 Inch Valve	92-477-1-108
4	Flat Washer, 1-1/2 Inch Valve, M12	4	(a)		3 Inch Valve	92-477-1-110
	2 & 3 Inch Valves, M16	4	(a)		Includes Items 3-6	
	4 & 6 Inch Valves, M16	8	(a)		4 Inch Valve	92-477-1-102
	8 Inch Valves, M20	8	(a)		6 Inch Valve	92-477-1-104
5	Hex Bolt, 1-1/2 Inch Valve, M12 x 30	4	(a)	(b)	Diaphragm Kit, Includes Item 2	
	2 & 3 Inch Valves, M16 x 50	4	(a)		1-1/2 Inch Valve	92-477-1-105
	4 Inch Valve, M16 x 50	6	(a)		2 Inch Valve	92-477-1-107
	6 Inch Valve, M16 x 55	6	(a)		3 Inch Valve	92-477-1-109
	8 Inch Valve, M20 x 70	6	(a)		4 Inch Valve	92-477-1-101
6	Hex Nut, 4 & 6 Inch Valves, M16	2	(a)		6 Inch Valve	92-477-1-103
	8 Inch Valves, M20	2	(a)		8 Inch Valve	92-477-1-111

NOTES:

- NR - Not Replaceable.
- 4, 6, & 8 Inch Valve Bodies are equipped with studs as shown, allowing Diaphragm and Handhole Cover to be "hung" in place to ease assembly. Bodies of 1-1/2, 2, and 3 Inch Valves are not equipped with studs.

FIGURE 1
1-1/2 thru 8 INCH (DN40 thru DN200) MODEL DV-5 DELUGE VALVE
— ASSEMBLY —

Nominal Valve Size ¹	Flange Drilling Specification														
	Nominal Dimensions in Inches and (mm)														
	ANSI B16.1 (Class 125) ²			ISO 7005-2 (PN10) ³			ISO 7005-2 (PN16) ⁴			JIS B 2210 (10K)			AS 2129 (Table E)		
	Dim. A	Dim. B	Qty. N	Dim. A	Dim. B	Qty. N	Dim. A	Dim. B	Qty. N	Dim. A	Dim. B	Qty. N	Dim. A	Dim. B	Qty. N
3 Inch (DN80)	6.00 (152,4)	0.75 (19,0)	4	USE ISO 2084 (PN16)			6.30 (160,0)	0.75 (19,0)	8	N/A			N/A		
4 Inch (DN100)	7.50 (190,5)	0.75 (19,0)	8				7.09 (180,0)	0.75 (19,0)	8	6.89 (175,0)	0.60 (15,0)	8	7.00 (178,0)	0.71 (18,0)	8
6 Inch (DN150)	9.50 (241,3)	0.88 (22,2)	8				9.45 (240,0)	0.91 (23,0)	8	9.45 (240,0)	0.75 (19,0)	8	9.25 (235,0)	0.87 (22,0)	8
8 Inch (DN200)	11.75 (298,5)	0.88 (22,2)	8	11.61 (295,0)	0.91 (23,0)	8	11.61 (295,0)	0.91 (23,0)	12	N/A			11.50 (292,0)	0.87 (22,0)	8

¹ Flange end 1-1/2 & 2 Inch (DN40 & DN50) DV-5 Valves are not offered.
² Same drilling as for B16.5 (Class 150) and B16.42 (Class 250).
³ Same drilling as for BS 4504 Section 3.2 (PN10) and DIN 2532 (PN10).
⁴ Same drilling as for BS 4504 Section 3.2 (PN16) and DIN 2532 (PN16).

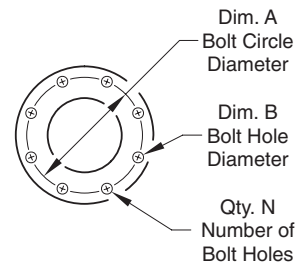

TABLE A — DIMENSIONAL SPECIFICATIONS FOR SELECTION OF FLANGE DRILLING

Port Description	Port	Port Sizes in NPT per ANSI B1.20.1 *					
		1-1/2 Inch (DN40)	2 Inch (DN50)	3 Inch (DN80)	4 Inch (DN100)	6 Inch (DN150)	8 Inch (DN200)
Diaphragm Chamber Supply	P1	1/2"	1/2"	1/2"	1/2"	1/2"	1/2"
Water Supply Pressure & Alarm Test	P2	1/2"	1/2"	1/2"	1/2"	1/2"	1/2"
Alarm Actuation & System Drain	P3	3/4"	3/4"	3/4"	1"	1"	1"
Main Drain	P4	3/4"	3/4"	1-1/4"	2"	2"	2"
Diaphragm Chamber Supply Automatic Shut-Off Valve Actuation	P5	1/2"	1/2"	1/2"	1/2"	1/2"	1/2"

* Valves are available with ports threaded per ISO 7/1.

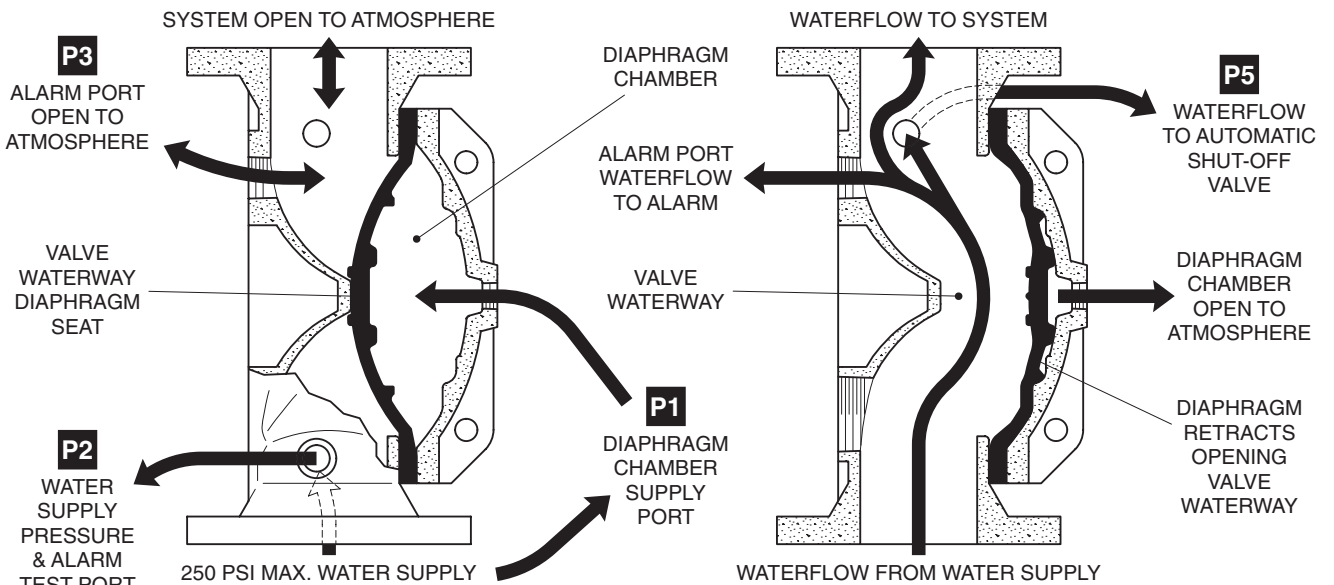

FIGURE 2A
SET POSITION

FIGURE 2B
OPERATED POSITION

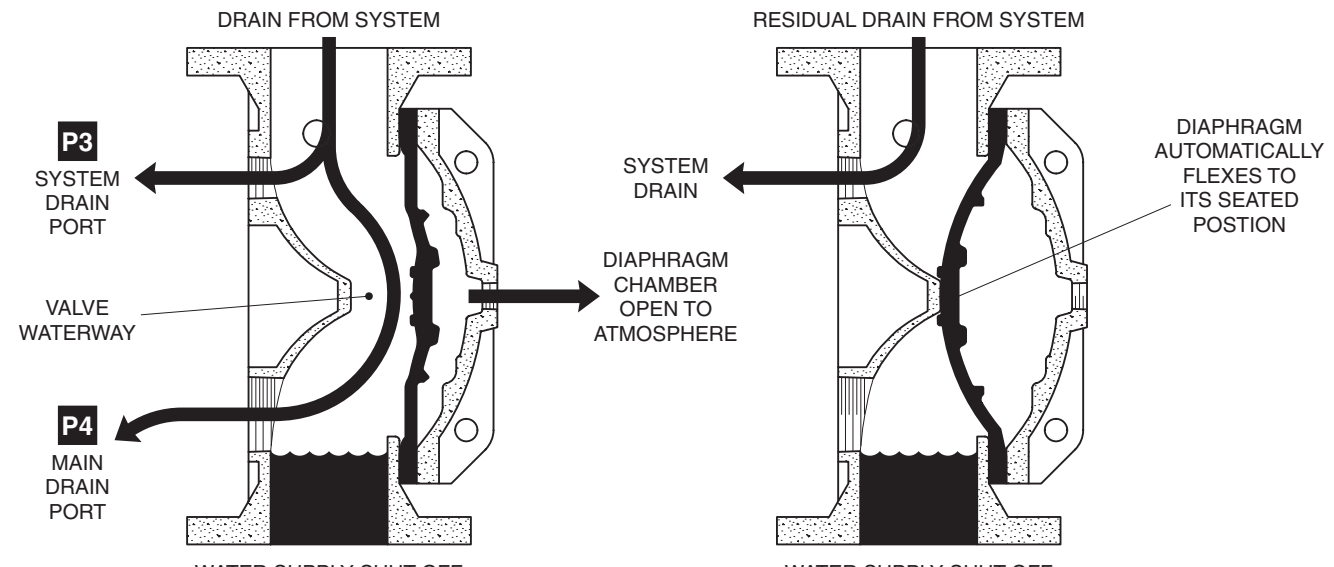
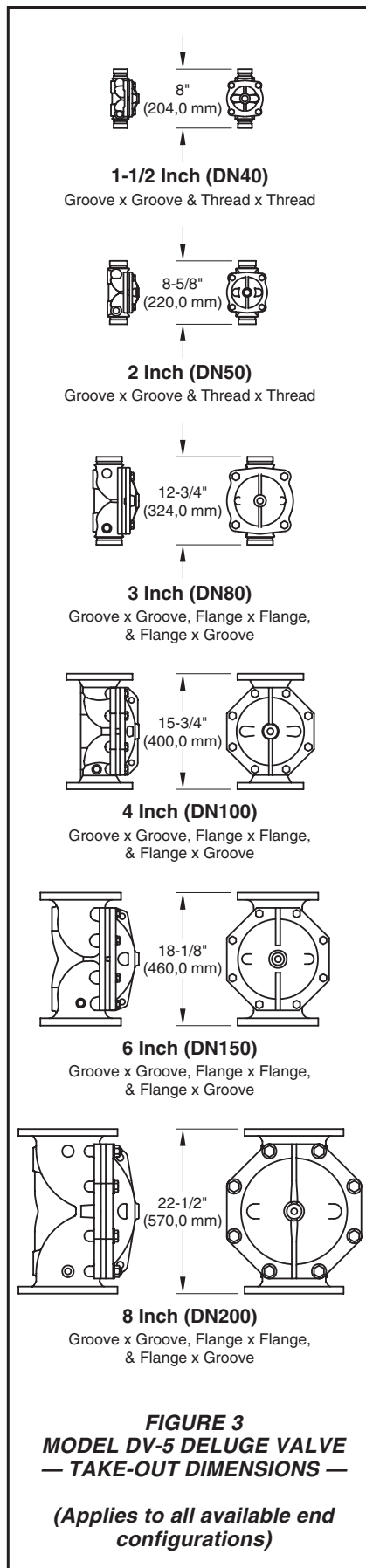

FIGURE 2C
SYSTEM DRAIN POSITION

FIGURE 2D
RESIDUAL DRAIN POSITION

FIGURE 2
1-1/2 thru 8 INCH (DN40 thru DN200) MODEL DV-5 DELUGE VALVE
— SET AND OPEN POSITIONS —



Technical Data

Approvals:

UL Listed, C-UL Listed, and FM Approved, when trimmed per the following Technical Data Sheets:

Deluge Systems:

TFP1310 - Wet Pilot Actuation
TFP1315 - Dry Pilot Actuation
TFP1320 - Electric Actuation

Single Interlock Preaction Systems:

TFP1410 - Wet Pilot Actuation*
TFP1415 - Dry Pilot Actuation*
TFP1420 - Electric Actuation

*UL and C-UL only.

Double Interlock Preaction Systems:

TFP1460 - Electric/Pneumatic
TFP1465 - Electric/Electric

Deluge Valve:

Components for the 1-1/2 thru 8 inch (DN40 thru DN200), Model DV-5 Deluge Valves are shown in Figure 1. The DV-5 Valves are for vertical or horizontal installations, and they are rated for use at a maximum service pressure of 250 psi (17,2 bar).

The take-out dimensions are shown in Figure 3, and the flanged connections are available drilled per ANSI, ISO, AS, and JIS specifications (Ref. Table A).

Threaded port connections of the DV-5 Valves are available NPT threaded or threaded per ISO 7/1 as detailed in the Ordering Procedure section. Valves with NPT threaded ports will readily accept the trim arrangements detailed in Technical Data Sheets referenced under "Approvals".

Patents:

U.S.A. : 6,095,484

Materials Of Construction

NOTES

The Rilsan coating for the DV-5 Valve provides corrosion resistance and is intended to extend the life of the DV-5 Valve when exposed to internal and external corrosive conditions. Although the Rilsan coating is intended to resist corrosion, it is recommended that the end user or other technical expert familiar with conditions at the proposed installation be consulted with respect to the suitability of this coating for a given corrosive condition.

Deluge systems using a seawater or brackish water supply require special considerations in order to extend the life of the valve and trim. This type of system ideally should be configured with a primary source of clean fresh water (e.g., a pressurized water tank) and only upon system operation is the secondary water supply (seawater or brackish water) allowed to enter the system. After the system operation, the system should then be thoroughly flushed with clean fresh water. Following this recommendation will increase the service life of the DV-5 Valve and Valve Trim.

Body. Rilsan* coated ductile iron per ASTM A536-77, Grade 65-45-12.

Handhole Cover. Rilsan* coated ductile iron per ASTM A536-77, Grade 65-45-12.

Diaphragm. Nylon fabric reinforced, natural rubber per ASTM D2000.

V-Ring. Natural rubber per ASTM D2000.

Diaphragm Cover Fasteners. Galvanized carbon steel.

*Rilsan is a registered trademark of ATOFINA Chemicals, Inc. (The Rilsan coating is a polyamide (Nylon 11) coating.)

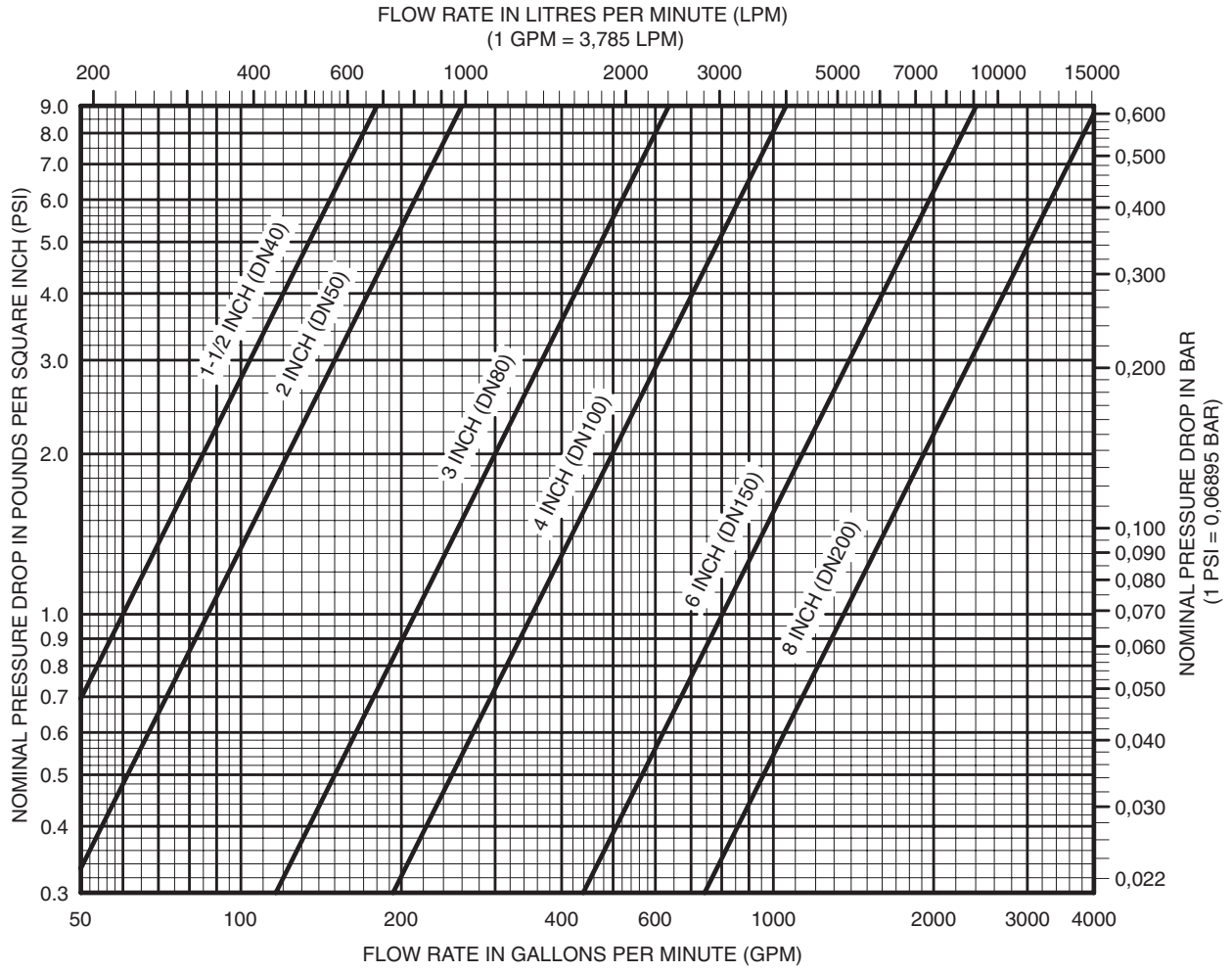

The approximate friction loss, based on the Hazen and Williams formula and expressed in equivalent length of pipe with C=120, is as follows:

- 9 feet of 1-1/2 Sch. 40 pipe for the 1-1/2 inch DV-5 Valve calculated on a typical flow rate of 100 GPM.
- 16 feet of 2 inch Sch. 40 pipe for the 2 inch DV-5 Valve calculated on a typical flow rate of 175 GPM.
- 20 feet of 3 inch Sch. 40 pipe for the 3 inch DV-5 Valve calculated on a typical flow rate of 350 GPM.
- 29 feet of 4 inch Sch. 40 pipe for the 4 inch DV-5 Valve calculated on a typical flow rate of 600 GPM.
- 46 feet of 6 inch Sch. 40 pipe for the 6 inch DV-5 Valve calculated on a typical flow rate of 1500 GPM.
- 72 feet of 8 inch Sch. 30 pipe for the 8 inch DV-5 Valve calculated on a typical flow rate of 2500 GPM.

GRAPH A
1-1/2 thru 8 INCH (DN40 thru DN200) MODEL DV-5 DELUGE VALVE
— NOMINAL PRESSURE LOSS VERSUS FLOW —

Operating Principles

The Model DV-5 Deluge Valve is a diaphragm style valve that depends upon water pressure in the Diaphragm Chamber (Ref. Figure 2A) to hold the Diaphragm closed against the water supply pressure. When the DV-5 Valve is set for service, the Diaphragm Chamber is pressurized through the trim connections from the inlet side of the system's main control valve. Open-

ing an actuation device, for example the solenoid valve in the Electric Actuation Trim (Ref. Technical Data Sheet TFP1320), releases water from the Diaphragm Chamber faster than it can be replenished through an 1/8 inch (3,2 mm) restriction provided by the diaphragm chamber supply connection provided in the applicable trim arrangements. This results in a rapid pressure drop in the Diaphragm Chamber and the force differential applied through the Diaphragm to hold the Diaphragm in the set position is

reduced below the valve trip point. The water supply pressure then forces the Diaphragm open permitting water to flow into the system piping, as well as through the Alarm Port to actuate the system alarms (Ref. Figure 2B).

Installation

NOTES

Proper operation of the Model DV-5 Deluge Valves depends upon their trim being installed in accordance with the instructions given in their respective Technical Data Sheet. Failure to follow the appropriate trim diagram may prevent the DV-5 Valve from functioning properly, as well as void listings, approvals, and the manufacturer's warranties.

The DV-5 Valve must be installed in a readily visible and accessible location.

The DV-5 Valve, associated trim, and wet pilot lines must be maintained at a minimum temperature of 40°F/4°C.

Heat tracing of the DV-5 Valve or its associated trim is not permitted. Heat tracing can result in the formation of hardened mineral deposits that are capable of preventing proper operation.

Before a system hydrostatic test is performed refer to the Installation section of Technical Data Sheet TFP1310, TFP1315, TFP1320, TFP1410, TFP1415, TFP1420, TFP1460, or TFP1465.

Care and Maintenance

The following procedures and inspections must be performed as indicated, in addition to any specific requirements of the NFPA, and any impairment must be immediately corrected.

The owner is responsible for the inspection, testing, and maintenance of their fire protection system and devices in compliance with this document, as well as with the applicable standards of the National Fire Protection Association (e.g., NFPA 25), in addition to the standards of any authority having jurisdiction. The installing contractor or product manufacturer should be contacted relative to any questions.

It is recommended that automatic sprinkler systems be inspected, tested, and maintained by a qualified Inspection Service in accordance with local requirements and/or national codes.

NOTES

When the system is using either a seawater or brackish water supply, internal and external inspection of the DV-5 Valve and Trim is essential. Parts showing any signs of corrosion must be replaced to ensure the integrity of the system.

Before closing a fire protection system main control valve for maintenance work on the fire protection system that it controls, permission to shut down the affected fire protection systems must first be obtained from the proper authorities and all personnel who may be affected by this action must be notified.

Drop In Water Supply Pressure Below Normal Range

NOTE

If the water supply pressure is significantly reduced below the normally expected static pressure range (as could occur in the case of a water main break or repair), and there is a subsequent drop in the diaphragm chamber water pressure below its normal range (due, for example, to a leak in a piping connection to or from the diaphragm chamber or, a leak in the diaphragm chamber check valve caused by dirt or debris in the check valve seal area), a deluge valve such as the Model DV-5 could inadvertently trip, if its water supply pressure is quickly restored.

A drop in the water supply pressure to below its normal range (as in the case of an interrupted water supply condition) constitutes an emergency impairment as defined by NFPA 25. Should this condition occur, **immediately close the main control valve** and utilize the following procedure to reset the system:

Step 1. Prior to the water supply pressure being restored to the closed main control valve, note the pressure indicated by the diaphragm chamber pressure gauge and determine if the pressure is within the normally expected range.

Step 2. If the diaphragm chamber pressure is below the normal range, check for and correct any source of leakage from the diaphragm chamber prior to resetting the system.

Step 3. After the water supply pressure is restored to the main control valve, reset the Model DV-5 Deluge Valve in accordance with the Valve Setting Procedure section.

NOTE

For fire protection systems subject to an emergency impairment caused by an interrupted water supply condition, it is recommended that consideration be given to installing a low water supply pressure switch with the appropriate alarm/indications to monitor the water supply pressure.

Annual Operation Test Procedure

Proper operation of the DV-5 Valve (i.e., opening of the DV-5 Valve as

during a fire condition) must be verified at least once a year as follows:

NOTE

Operation tests for DV-5 Valves used in double interlock preaction systems must be performed as outlined in TFP1460 or TFP1465, as applicable.

Step 1. If water must be prevented from flowing beyond the riser, perform the following steps.

- Close the Main Control Valve.
- Open the Main Drain Valve.
- Open the Main Control Valve one turn beyond the position at which water just begins to flow from the Main Drain Valve.
- Close the Main Drain Valve.

Step 2. Determine the type of actuation/detection system, and operate the DV-5 Valve accordingly.

NOTE

Be prepared to quickly perform Steps 3, 4, and 5, if water must be prevented from flowing beyond the riser.

- **Wet Pilot Actuation** — Open the Inspector's Test Connection.
- **Dry Pilot Actuation** — Open the Inspector's Test Connection.
- **Electric Actuation** — Test the deluge releasing panel (automatic control unit) in accordance with the manufacturer's instructions to energize the solenoid valve.

Step 3. Verify that the DV-5 Valve has tripped, as indicated by the flow of water into the system.

Step 4. Close the system's Main Control Valve.

Step 5. Close the Diaphragm Chamber Supply Control Valve.

Step 6. Reset the DV-5 Deluge Valve in accordance with the Valve Setting Procedure provided in TFP1310, TFP1315, TFP1320, TFP1410, TFP1415, or TFP1420, as applicable.

Internal Valve Inspection

Once every five years during the annual operational test procedure and prior to the DV-5 Valve being reset, the interior of the DV-5 Valve must be cleaned and inspected for wear and damage. Damaged or worn parts must be replaced. (Replacement of the Diaphragm every ten years is recommended.)

When reinstalling the Diaphragm Cover, the Diaphragm Cover Fasten-

ers must be uniformly and securely tightened using a cross-draw sequence. After tightening, double-check to make certain that all of the Diaphragm Cover Fasteners are securely tightened.

NOTES

If the water supply contains chemicals which tend to attack a Nylon fabric reinforced, natural rubber or the five year inspection indicates a build-up of debris within the valve that could affect its proper operation, then the frequency of the internal valve inspection procedure must be appropriately increased.

If the system has a seawater or brackish water supply, then the frequency of the internal valve inspection procedure must be appropriately increased. (An annual internal valve inspection for a system having a seawater or brackish water supply is recommended.)

With reference to Figure 1, make certain that the Diaphragm is correctly oriented; otherwise, the DV-5 cannot be properly set.

Under-tightening the Diaphragm Cover Bolts can result in leakage past the valve seat as indicated by leakage from the Automatic Drain Valve.

Limited Warranty

Products manufactured by Tyco Fire & Building Products are warranted solely to the original Buyer for ten (10) years against defects in material and workmanship when paid for and properly installed and maintained under normal use and service. This warranty will expire ten (10) years from date of shipment by Tyco Fire & Building Products. No warranty is given for products or components manufactured by companies not affiliated by ownership with Tyco Fire & Building Products or for products and components which have been subject to misuse, improper installation, corrosion, or which have not been installed, maintained, modified or repaired in accordance with applicable Standards of the National Fire Protection Association, and/or the standards of any other Authorities Having Jurisdiction. Materials found by Tyco Fire & Building Products to be defective shall be either repaired or replaced, at Tyco Fire & Building Products' sole option. Tyco Fire & Building Products neither assumes, nor authorizes any person to assume for it, any other obligation in connection with the sale of products or parts of products.

Tyco Fire & Building Products shall not be responsible for sprinkler system design errors or inaccurate or incomplete information supplied by Buyer or Buyer's representatives.

IN NO EVENT SHALL TYCO FIRE & BUILDING PRODUCTS BE LIABLE, IN CONTRACT, TORT, STRICT LIABILITY OR UNDER ANY OTHER LEGAL THEORY, FOR INCIDENTAL, INDIRECT, SPECIAL OR CONSEQUENTIAL DAMAGES, INCLUDING BUT NOT LIMITED TO LABOR CHARGES, REGARDLESS OF WHETHER TYCO FIRE & BUILDING PRODUCTS WAS INFORMED ABOUT THE POSSIBILITY OF SUCH DAMAGES, AND IN NO EVENT SHALL TYCO FIRE & BUILDING PRODUCTS' LIABILITY EXCEED AN AMOUNT EQUAL TO THE SALES PRICE.

THE FOREGOING WARRANTY IS MADE IN LIEU OF ANY AND ALL OTHER WARRANTIES EXPRESS OR IMPLIED, INCLUDING WARRANTIES OF MERCHANTABILITY AND FITNESS FOR A PARTICULAR PURPOSE.

Ordering Procedure

NOTES

Refer to Table A for Flange Drilling Specifications.

Part Numbers for factory pre-trimmed Model DV-5 Valves are provided in the Price Book.

Standard DV-5 Deluge Valve (American Standard Flange Drilling, Threaded Ports, and Groove Outside Diameter, as applicable):

Specify: (specify size inch) Model DV-5 Deluge Valve with (specify end connections), P/N (specify).

1-1/2 Inch G x G 1.90 inch (48,3 mm) Groove O.D. x 1.90 inch (48,3 mm) Groove O.D.	P/N 52-477-1-919
1-1/2 Inch T x T NPT x NPT	P/N 52-477-1-069
2 Inch G x G 2.37 inch (60,3 mm) Groove O.D. x 2.37 inch (60,3 mm) Groove O.D.	P/N 52-477-1-910
2 Inch T x T NPT x NPT	P/N 52-477-1-060
3 Inch G x G 3.50 inch (88,9 mm) Groove O.D. x 3.50 inch (88,9 mm) Groove O.D.	P/N 52-477-1-912

3 Inch F x F ANSI Flange x ANSI Flange	P/N 52-477-1-012
3 Inch F x G ANSI Flange x 3.50 inch (88,9 mm) Groove O.D.	P/N 52-477-1-412
4 Inch G x G 4.50 inch (114,3 mm) Groove O.D. x 4.50 inch (114,3 mm) Groove O.D.	P/N 52-477-1-913
4 Inch F x F ANSI Flange x ANSI Flange	P/N 52-477-1-013
4 Inch F x G ANSI Flange x 4.50 inch (114,3 mm) Groove O.D.	P/N 52-477-4-613
6 Inch G x G 6.62 inch (168,3 mm) Groove O.D. x 6.62 inch (168,3 mm) Groove O.D.	P/N 52-477-1-915
6 Inch F x F ANSI Flange x ANSI Flange	P/N 52-477-1-015
6 Inch F x G ANSI Flange x 6.62 inch (168,3 mm) Groove O.D.	P/N 52-477-4-615
8 Inch G x G 8.62 inch (219,1 mm) Groove O.D. x 8.62 inch (219,1 mm) Groove O.D.	P/N 52-477-1-916
8 Inch F x F ANSI Flange x ANSI Flange	P/N 52-477-1-016
6 Inch F x G ANSI Flange x 8.62 inch (219,1 mm) Groove O.D.	P/N 52-477-1-416

Replacement Valve Parts:

Specify: (description) for use with (specify) size Model DV-5 Deluge Valve, P/N (see Figure 1).

Other DV-5 Deluge Valves:

NOTES

Other DV-5 Deluge Valves are valves ordered with any combination of flange, threaded port, or groove outside diameter not offered under "Standard DV-5 Deluge Valve" offerings.

Valves with NPT threaded ports are intended for use with the "Standard DV-5 Valve Trim" offered and detailed in Technical Data Sheets TFP1310, TFP1315, TFP1320, TFP1410, TFP1415, TFP1420, TFP1460, and TFP1465. Valves with ISO threaded ports are intended for use with special order trim that is provided by local distributors to meet the specific needs of certain localities. Please contact your local distributor regarding valves and valve trim for specific localities.

Specify: (specify size) Model DV-5 Deluge Valve with (specify) connections with (specify NPT or ISO) threaded ports, P/N (See Page 8).

Part Numbers For Other Model DV-5 Deluge Valves:

Other 1-1/2 Inch Valves with ISO Ports
 ISO Thread x
 ISO Thread P/N 52-477-1-169

Other 2 Inch Valves with ISO Ports
 ISO Thread x
 ISO Thread P/N 52-477-1-160

Other 3 Inch Valves with NPT Ports
 ISO Flange x
 3.50 inch (88,9 mm)
 Groove O.D. P/N 52-477-1-252
 ISO Flange x
 ISO Flange P/N 52-477-1-132
 AS Flange x
 AS Flange P/N 52-477-1-512
 AS Flange x
 3.50 inch (88,9 mm)
 Groove O.D. P/N 52-477-1-612
 JIS Flange x
 JIS Flange P/N 52-477-1-712
 JIS Flange x
 3.50 inch (88,9 mm)
 Groove O.D. P/N52-477-1-812

Other 3 Inch Valves with ISO Ports
 ISO Flange x
 ISO Flange P/N 52-477-1-112
 ISO Flange x
 3.50 inch (88,9 mm)
 Groove O.D. P/N 52-477-1-212
 3.50 inch (88,9 mm)
 Groove O.D x
 3.50 inch (88,9 mm)
 Groove O.D. P/N 52-477-1-922

Part Numbers For Other Model DV-5 Deluge Valves:

Other 4 Inch Valves with NPT Ports
 ISO Flange x
 4.50 inch (114,3 mm) Groove O.D. P/N 52-477-5-213
 ISO Flange x
 ISO Flange P/N 52-477-5-113
 AS Flange x
 AS Flange P/N 52-477-4-313
 AS Flange x
 4.50 inch (114,3 mm) Groove O.D. P/N 52-477-4-413
 JIS Flange x
 JIS Flange P/N 52-477-4-713
 JIS Flange x
 4.50 inch (114,3 mm) Groove O.D. P/N 52-477-4-813

Other 4 Inch Valves with ISO Ports
 ISO Flange x
 ISO Flange P/N 52-477-4-113
 ISO Flange x
 4.50 inch (114,3 mm) Groove O.D. P/N 52-477-4-213
 4.50 inch (114,3 mm) Groove O.D x
 4.50 inch (114,3 mm) Groove O.D. P/N 52-477-1-923

Other 6 Inch Valves with NPT Ports
 ANSI Flange x
 6.50 inch (165,1 mm) Groove O.D. P/N 52-477-4-225
 ISO Flange x
 6.62 inch (168,3 mm) Groove O.D. P/N 52-477-5-625
 ISO Flange x
 6.50 inch (165,1 mm) Groove O.D. P/N 52-477-5-215
 ISO Flange x
 ISO Flange P/N 52-477-5-115
 6.50 inch (165,1 mm) Groove O.D x
 6.50 inch (165,1 mm) Groove O.D. P/N 52-477-1-935
 AS Flange x
 AS Flange P/N 52-477-4-315
 AS Flange x
 6.62 inch (168,3 mm) Groove O.D. P/N 52-477-4-415
 AS Flange x
 6.50 inch (165,1 mm) Groove O.D. P/N 52-477-5-415
 JIS Flange x
 JIS Flange P/N 52-477-4-715
 JS Flange x
 6.62 inch (168,3 mm) Groove O.D. P/N 52-477-4-815
 JS Flange x
 6.50 inch (165,1 mm) Groove O.D. P/N 52-477-5-815

Other 6 Inch Valves with ISO Ports
 ISO Flange x
 ISO Flange P/N 52-477-4-115
 ISO Flange x
 6.62 inch (168,3 mm) Groove O.D. P/N 52-477-4-625
 ISO Flange x
 6.50 inch (165,1 mm) Groove O.D. P/N 52-477-4-215
 6.62 inch (168,3 mm) Groove O.D x
 6.62 inch (168,3 mm) Groove O.D. P/N 52-477-1-925
 6.50 inch (165,1 mm) Groove O.D x
 6.50 inch (165,1 mm) Groove O.D. P/N 52-477-1-945

Part Numbers For Other Model DV-5 Deluge Valves:

Other 8 Inch Valves with NPT Ports
 ISO (PN10) Flange x
 8.62 inch (219,1 mm) Groove O.D. P/N 52-477-1-256
 ISO (PN16) Flange x
 8.62 inch (219,1 mm) Groove O.D. P/N 52-477-1-216
 ISO (PN10) Flange x
 ISO (PN10) Flange P/N 52-477-1-136
 ISO (PN16) Flange x
 ISO (PN16) Flange P/N 52-477-1-146
 AS Flange x
 AS Flange P/N 52-477-1-516
 AS Flange x
 8.62 inch (219,1 mm) Groove O.D. P/N 52-477-1-616
 JIS Flange x
 JIS Flange P/N 52-477-1-716
 JS Flange x
 8.62 inch (219,1 mm) Groove O.D. P/N 52-477-1-816

Other 8 Inch Valves with ISO Ports
 ISO (PN10) Flange x
 ISO (PN10) Flange P/N 52-477-1-116
 ISO (PN16) Flange x
 ISO (PN16) Flange P/N 52-477-1-126
 ISO (PN10) Flange x
 8.62 inch (219,1 mm) Groove O.D. P/N 52-477-1-216
 ISO (PN16) Flange x
 8.62 inch (219,1 mm) Groove O.D. P/N 52-477-1-226
 8.62 inch (219,1 mm) Groove O.D. x
 8.62 inch (219,1 mm) Groove O.D. P/N 52-477-1-926