

## **Model DV-5 Red-E Cabinet 1-1/2 thru 6 Inch (DN40 thru DN150), 250 psi (17,2 bar) Integrated Deluge Fire Protection Package**

### **General Description**

The Model DV-5 Red-E Cabinet is a pre-assembled fire protection valve package enclosed within a free-standing cabinet designed to occupy minimal floor space and to provide an aesthetically pleasing enclosure for a fire protection valve riser. The entire package is pre-wired and the water inlet and outlets to the valve riser are grooved to provide minimal installation time. The valve package includes the system (manual) shut-off control valve, automatic water control valve, and waterflow/supervisory switches. When dry pilot actuation is utilized, a built-in air compressor with associated controls provides an automatic air supply for the dry pilot lines.

Integral to the DV-5 Red-E Cabinet is a control panel and back-up batteries for providing electrical alarm, supervisory, and trouble functions. All switches within the cabinet are pre-wired to the control panel, making the electrical connections for power, detection circuits (as applicable), and alarms the only remaining connections to complete the system.

In addition to the control panel being integral to the DV-5 Red-E Cabinet, windows have been provided in the door for viewing the releasing panel functions and essential system pressure gauges. A lock for the control panel access door is standard, and a lock for the cabinet door is optional.

Features and benefits are as follows:

- Aesthetically pleasing appearance
- Professionally assembled
- Internally wired
- Custom manufactured
- All gauges and panel display are externally visible



- Removable side panels for ease of maintenance
- Furniture grade rollers (4) are standard at bottom of cabinet

The DV-5 Red-E Cabinet has been designed to readily incorporate 1-1/2 thru 6 inch (DN40 thru DN150) valve risers for the following types of deluge systems:

- Electric Actuation
- Dry Pilot Actuation
- Wet Pilot Actuation

#### **WARNING**

*The Model DV-5 Red-E Cabinets described herein must be installed and maintained in compliance with this document, as well as with the applicable standards of the National Fire Protection Association, in addition to the standards of any other authorities having jurisdiction. **Failure to do so may impair the performance of these devices.***

*The owner is responsible for maintaining their fire protection system and devices in proper operating condition. The installing contractor or sprinkler manufacturer should be contacted with any questions.*

Port	Connection Description	Nominal Riser Size				
		Small Cabinet			Large Cabinet	
		1-1/2 Inch (DN40)	2 Inch (DN50)	3 Inch (DN80)	4 Inch (DN100)	6 Inch (DN150)
A	Supply Header	1-1/2" (38,1 mm)	2" (50,8 mm)	3" (76,2 mm)	4" (101,6 mm)	6" (152,4 mm)
B	System Discharge	1-1/2" (38,1 mm)	2" (50,8 mm)	3" (76,2 mm)	4" (101,6 mm)	6" (152,4 mm)
C	Drain Header	3/4" NPT	3/4" NPT	1-1/4" NPT	2" (50,8 mm)	2" (50,8 mm)
D	Drip Funnel Drain	1-1/4" NPT	1-1/4" NPT	1-1/4" NPT	1-1/4" NPT	1-1/4" NPT

- Notes: 1. Connections are Grooved except where noted by NPT thread designations.  
 2. All connections except System Discharge are made internal to cabinet.

Cabinet Size	Nominal Dimensions in Inches and (millimeters)										
	E	F	G	H	J	K	L	M	N	P	R
Small	69-1/4 (1759,0)	28-1/2 (723,9)	22-3/4 (577,9)	13-1/4 (336,6)	10 (254,0)	4 (101,6)	5 (127,0)	10 (254,0)	10-1/8 (257,2)	4 (101,6)	4-1/4 (108,0)
Large	75-7/8 (1927,2)	36 (914,4)	31 (787,4)	18 (457,2)	14-1/8 (358,8)	2 (50,8)	7 (177,8)	14-1/8 (358,8)	11-3/16 (284,2)	6-1/8 (155,6)	5-3/16 (131,8)

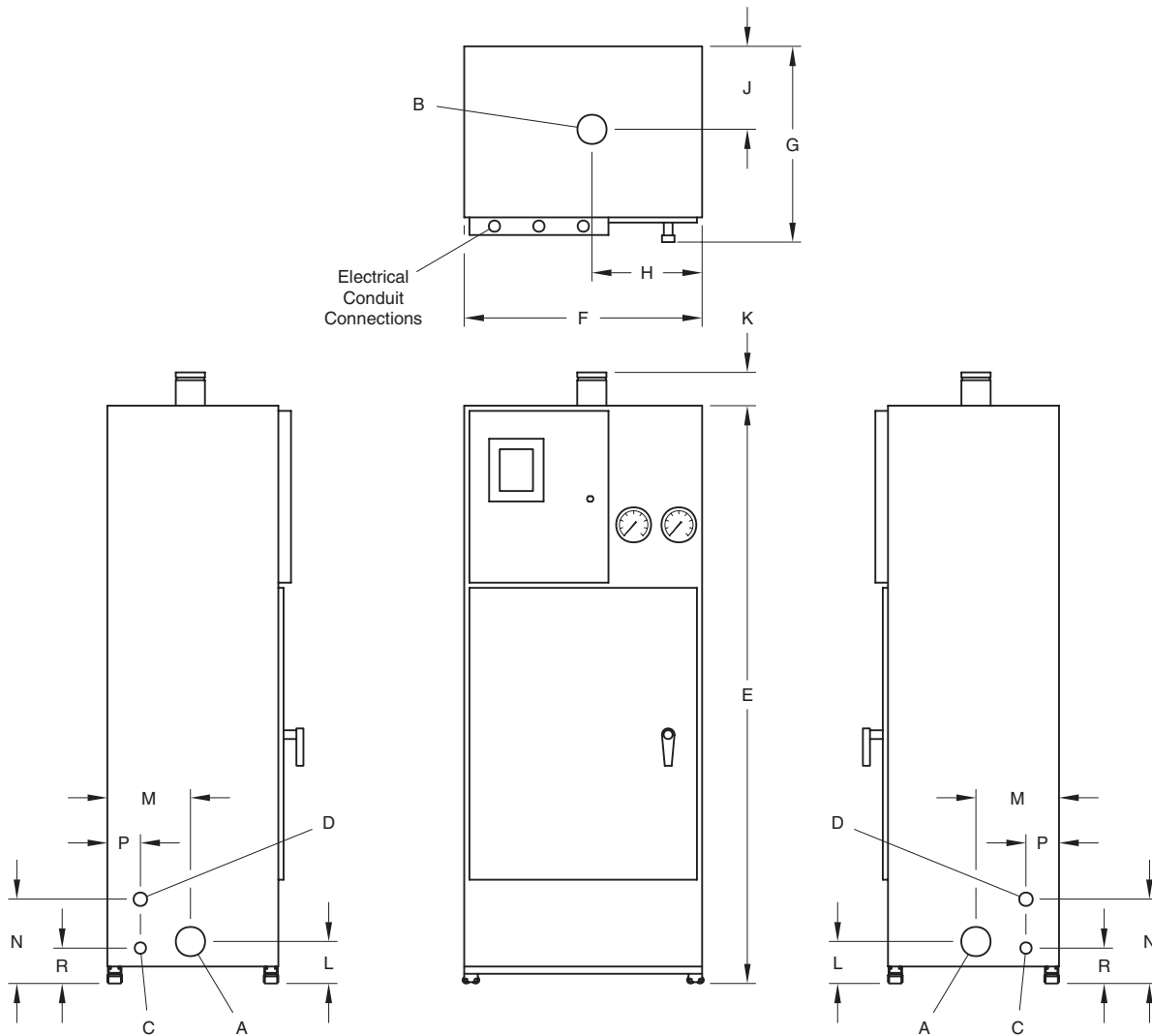

**FIGURE 1**  
**INSTALLATION DIMENSIONS AND REFERENCE POINTS**

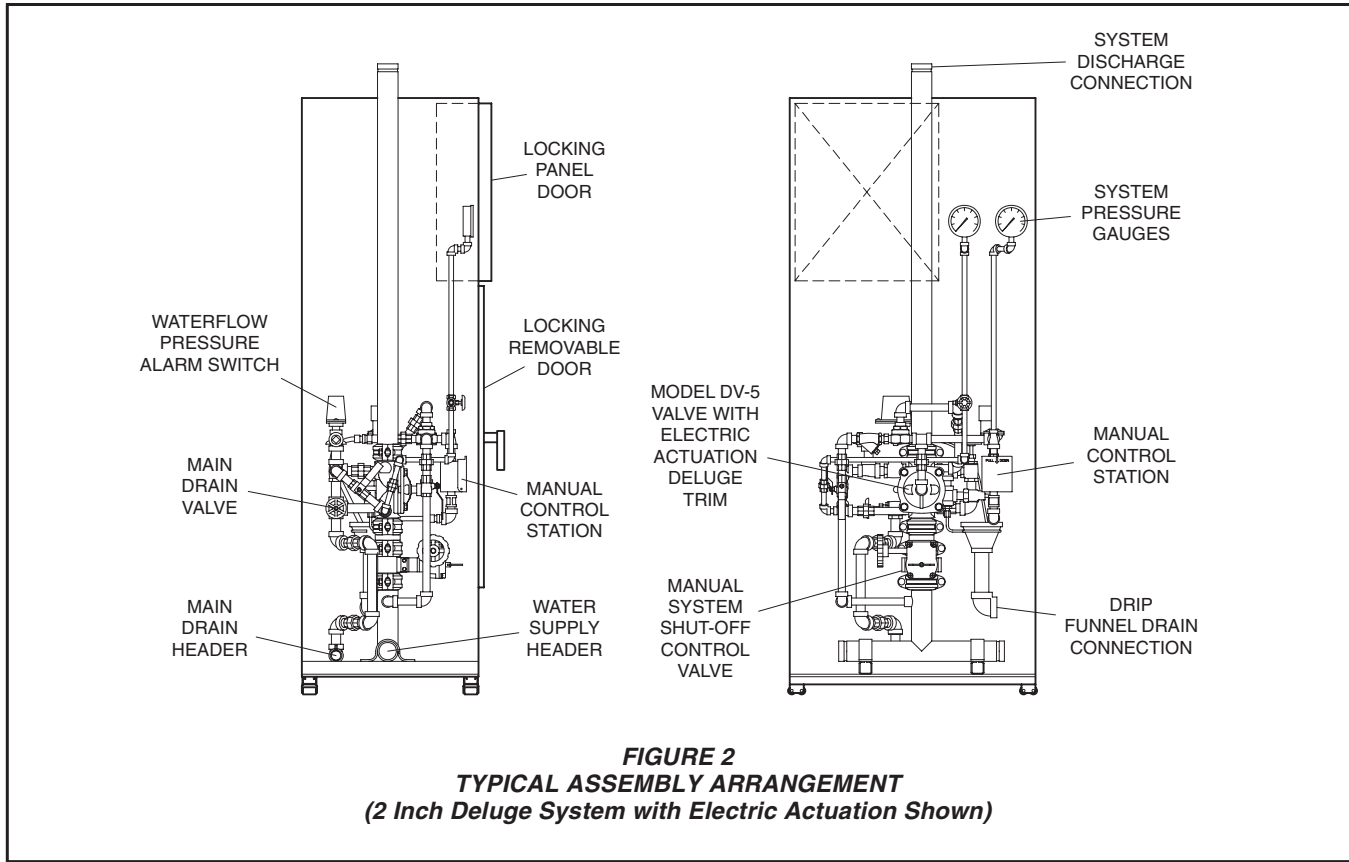

**FIGURE 2**  
**TYPICAL ASSEMBLY ARRANGEMENT**  
**(2 Inch Deluge System with Electric Actuation Shown)**

## Technical Data

### Approvals:

The riser components within the Red-E Cabinet are laboratory approved as indicated in Table A. The Red-E Cabinet which incorporates listed and/or approved riser components, as well as off-the-shelf industry accepted electrical junction boxes and wiring connections, meets the requirements of NFPA 13; consequently, the Red-E Cabinet does not need laboratory approval to be accepted by an Authority Having Jurisdiction.

### System Types:

The Technical Data Sheets referenced in Table B provide complete details for each system type arrangement.

### Working Pressure Range:

20 to 250 psi (1,4 to 17,2 bar).

### Construction

The Red-E Cabinet is constructed of 14 gauge steel, and is free standing. The standard paint finish is bright red. The front door of the enclosure is fully hinged (and removable) to maximize access to the enclosure. All four sides of the cabinet can be removed for ease of maintenance, and furniture grade

rollers at the bottom of the cabinet are standard. Internal controls that provide functions to reset a system after operation (e.g., alarm test valve, main drain valve, etc.) are individually tagged for easy identification. All prefabricated piping is Schedule 40 steel.

Table A provides list of riser components and a cross reference to individual Technical Data Sheets, as well as individual component laboratory approval information.

Figure 1 provides dimensional information for Red-E Cabinets, and Figure 2 illustrates the typical assembly arrangement.

## Design Considerations

The open nozzles and/or sprinklers, fire detection devices, manual pull stations, and signaling devices that are to be utilized with the Red-E Cabinet must be UL Listed, ULC Listed, C-UL Listed, or FM Approved, as applicable. With reference to Figure 3, the system designer must consider and make preparations for use of a Red-E Cabinet as follows:

- Adequate floor space to facilitate opening of the cabinet door.
- Minimum ambient temperature of 40°F/4°C.
- Installation of a suitably sized water supply to the water supply header Port A, Fig. 1).
- Installation of system piping (Port B, Fig. 1) including open nozzles and/or sprinklers from the Red-E cabinet outlet.
- Installation of drains from main drain header (Port C, Fig. 1) and drip funnel header (Port D, Fig. 1).
- Installation of the detection system components and alarms.
- Power supply to Red-E Cabinet.
- Separate power supply to the air compressor (dry pilot actuation).

Description	Model	Data Sheet	UL	C-UL/ULC	FM
System Shut-Off Valve	BFV-1	TFP1530	X	X	X
Automatic Water Control Valve	DV-5	TFP1305	X	X	X
Actuation Trim					
- Electric		TFP1320	X	X	X
- Dry Pilot		TFP1315	X	X	X
- Wet Pilot		TFP1310	X	X	X
Pressure Alarm Switch	PS10-2A		X <sup>(4)</sup>	X <sup>(4)</sup>	X <sup>(4)</sup>
Pressure Alarm Switch	PS40-2A		X <sup>(4)</sup>	X <sup>(4)</sup>	X <sup>(4)</sup>
Control Panel <sup>(1)</sup>	PFC-4410		X <sup>(4)</sup>	X <sup>(4)</sup>	X <sup>(4)</sup>
Air Maintenance Device <sup>(2)</sup> , Regulator Type	AMD-1	TFP1221	X	X	X
Air Maintenance Device <sup>(3)</sup> , Switch Type	AMD-2	TFP1231	X	X	X
Nitrogen Maintenance Device <sup>(3)</sup>	AMD-3	TFP1241	X	X	X

(1) The Model PFC-4410 is standard. The Red-E Cabinet may be ordered without an integral control panel.

(2) The Model AMD-1 Air Maintenance Device, in addition to an Auxiliary Air Tank, is utilized as standard equipment for Dry Pilot Actuation. In the case of Dry Pilot Actuation, the automatic air supply is utilized for the air pressure required for the dry pilot lines. An OL11016AC (1/6 HP) Air Compressor is provided as standard for maintaining the air pressure in the Auxiliary Air tank.

(3) The Model AMD-2 Air Maintenance Device and Model AMD-3 Nitrogen Maintenance Device, as well as the Model AMD-1 Air Maintenance Device, are offered as options when the Red-E Cabinet for Dry Pilot Actuation is ordered without a built-in automatic air supply (i.e., air compressor).

(4) Approvals under the name of Potter Electric Signal Company.

**TABLE A**  
**PRINCIPAL COMPONENTS**  
**— TECHNICAL DATA SHEETS AND LABORATORY APPROVALS —**

System Type	Refer To Following Technical Data Sheet (TFP) For Complete Operation Details
Deluge, Electric Actuation	TFP1320
Deluge, Dry Pilot Actuation	TFP1315
Deluge, Wet Pilot Actuation	TFP1310

**TABLE B**  
**SYSTEM TYPES AND OPERATION**

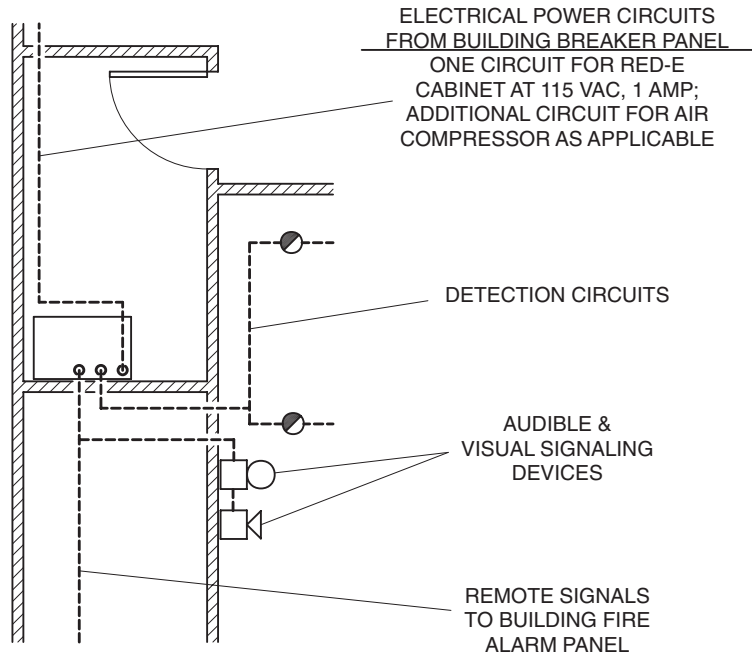

ELECTRICAL

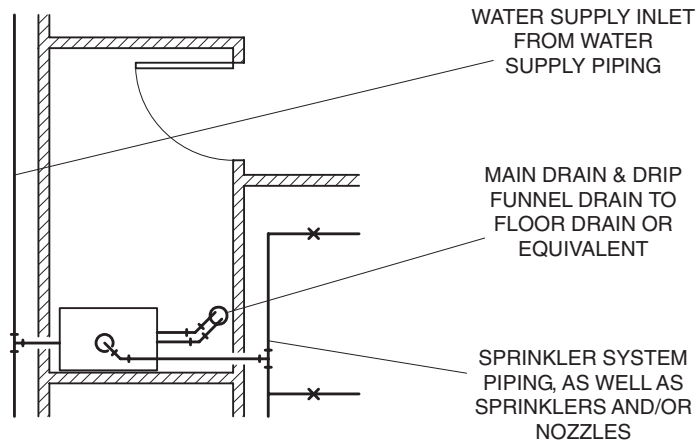

MECHANICAL

**FIGURE 3**  
**SYSTEM DESIGN CONSIDERATIONS**

## Installation

The Red-E Cabinet is to be installed following the directions given in the "Red-E Cabinet Installer's Manual" provided with the Red-E Cabinet. Instructions pertain to the following items:

- Placing the cabinet
- Connecting the system piping
- Electrical connections
- System start-up

## Care and Maintenance

Inspection, testing, and maintenance must be performed as in accordance with the requirements of the NFPA, and any impairment must be immediately corrected.

The Red-E Cabinet does not require any regularly scheduled inspection or maintenance. The riser components enclosed within the Red-E Cabinet, however, must be maintained in accordance with their applicable technical data sheet (refer to Table A). In addition, the Control Panel and Automatic Air Supply (as applicable) components must be maintained in accordance with their applicable instructions provided with the Red-E Cabinet.

The owner is responsible for the inspection, testing, and maintenance of their fire protection system and devices in compliance with this document, as well as with the applicable standards of any authorities having jurisdiction. The installing contractor or product manufacturer should be contacted relative to any questions.

It is also recommended that automatic sprinkler systems be inspected, tested, and maintained by a qualified Inspection Service in accordance with local requirements and/or national codes.

### NOTE

*Before closing a fire protection system main control valve for maintenance work on the fire protection system that it controls, permission to shut down the affected fire protection systems must first be obtained from the proper authorities and all personnel who may be affected by this decision must be notified.*

## Limited Warranty

Products manufactured by Tyco Fire Products are warranted solely to the original Buyer for ten (10) years against defects in material and workmanship when paid for and properly installed and maintained under normal use and service. This warranty will expire ten (10) years from date of shipment by Tyco Fire Products. No warranty is given for products or components manufactured by companies not affiliated by ownership with Tyco Fire Products or for products and components which have been subject to misuse, improper installation, corrosion, or which have not been installed, maintained, modified or repaired in accordance with applicable Standards of the National Fire Protection Association, and/or the standards of any other Authorities Having Jurisdiction. Materials found by Tyco Fire Products to be defective shall be either repaired or replaced, at Tyco Fire Products' sole option. Tyco Fire Products neither assumes, nor authorizes any person to assume for it, any other obligation in connection with the sale of products or parts of products. Tyco Fire Products shall not be responsible for sprinkler system design errors or inaccurate or incomplete information supplied by Buyer or Buyer's representatives.

IN NO EVENT SHALL TYCO FIRE PRODUCTS BE LIABLE, IN CONTRACT, TORT, STRICT LIABILITY OR UNDER ANY OTHER LEGAL THEORY, FOR INCIDENTAL, INDIRECT, SPECIAL OR CONSEQUENTIAL DAMAGES, INCLUDING BUT NOT LIMITED TO LABOR CHARGES, REGARDLESS OF WHETHER TYCO FIRE PRODUCTS WAS INFORMED ABOUT THE POSSIBILITY OF SUCH DAMAGES, AND IN NO EVENT SHALL TYCO FIRE PRODUCTS' LIABILITY EXCEED AN AMOUNT EQUAL TO THE SALES PRICE.

**THE FOREGOING WARRANTY IS MADE IN LIEU OF ANY AND ALL OTHER WARRANTIES EXPRESS OR IMPLIED, INCLUDING WARRANTIES OF MERCHANTABILITY AND FITNESS FOR A PARTICULAR PURPOSE.**

## Red-E Cabinet Technical Support

Technical support for the Red-E Cabinet is available by calling 888-572-4638 during regular business hours of 8:30-12:00 & 1:00-5:00 eastern time Monday through Friday.

The Red-E Cabinet Technical Support should be contacted "for special request cabinet configurations" or "electrical connection/control panel programming" inquiries.

An answering service will take messages outside of the regular business hours.

## Ordering Procedure

The following Part Numbers are provided for standard cabinets with integral control panel, built-in automatic air supply (i.e., air compressor and controls for dry pilot actuation), and galvanized pipe (except supply header which is black), nipples, and fittings.

*The Model DV-5 Red-E Cabinet can be provided as follows as part of a special request cabinet configuration:*

- *without the control panel*
- *without built-in automatic air supply (i.e., air compressor and controls for dry pilot actuation)*
- *with an optional air/nitrogen maintenance device when ordered without built-in automatic air supply for dry pilot actuation*
- *with trim black pipe, nipples, and fittings, as may be desired for AFFF systems*
- *with special size air compressors for dry pilot actuation*
- *with 50 Hz air compressors*
- *with supervised downstream system shut-off valve - allows for easy trip testing of the system*
- *with sight flow gage - provides a visual indication of flow through the main drain*
- *with extra capacity batteries (12V 12Ah) for longer battery time and/or systems with heavy power requirements (e.g. numerous audible signaling devices)*
- *with Class "A" initiating appliance circuits. This option permits the connection of Class "A" style wiring to the initiating zones*
- *with Class "A" indicating appliance circuits. This option permits the connection of Class "A" style wiring to the indicating zones*
- *with auxiliary relay modules to provide extra dry contacts when required - up to 4 ARM-2 modules per cabinet can be added*

Please contact "Red-E Cabinet Technical Support" group for information on special request cabinet configurations.

### Model DV-5 Red-E Cabinet With Deluge System

Specify: (size) Inch Model DV-5 Red-E Cabinet with (specify actuation) system riser for installation in (USA or Canada), P/N (specify).

#### NOTES

*For assemblies intended for use in Canada, change the "A" to a "C".*

*Assemblies intended for use in Canada are provided with Switches and a Control Panel that are specifically ULC Listed.*

*Dry Pilot Actuation is provided standard with a OL11016AC (1/6 HP) Air Compressor and Auxiliary Air Tank complete with one Model AMD-1 Air Maintenance Device.*

#### 1-1/2 INCH (USA)

Electric Actuation . . . . .	P/N 52-813-0-1A0
Dry Pilot Actuation . . . . .	P/N 52-812-0-1A1
Wet Pilot Actuation . . . . .	P/N 52-811-0-1A0

#### 2 INCH (USA)

Electric Actuation . . . . .	P/N 52-823-0-1A0
Dry Pilot Actuation . . . . .	P/N 52-822-0-1A1
Wet Pilot Actuation . . . . .	P/N 52-821-0-1A0

#### 3 INCH (USA)

Electric Actuation . . . . .	P/N 52-833-0-1A0
Dry Pilot Actuation . . . . .	P/N 52-832-0-1A1
Wet Pilot Actuation . . . . .	P/N 52-831-0-1A0

#### 4 INCH (USA)

Electric Actuation . . . . .	P/N 52-843-0-1A0
Dry Pilot Actuation . . . . .	P/N 52-842-0-1A1
Wet Pilot Actuation . . . . .	P/N 52-841-0-1A0

#### 6 INCH (USA)

Electric Actuation . . . . .	P/N 52-863-0-1A0
Dry Pilot Actuation . . . . .	P/N 52-862-0-1A1
Wet Pilot Actuation . . . . .	P/N 52-861-0-1A0

