



## DIRECTIONAL SPRAY NOZZLES, OPEN

### TYPE D3 PROTECTOSPRAY® — 1/2" NPT

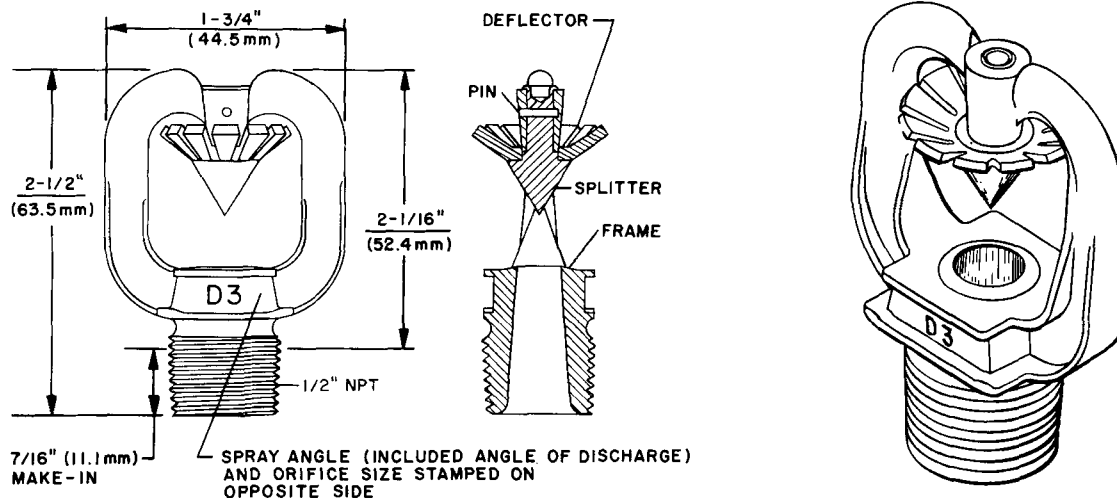

FIGURE A  
TYPE D3 PROTECTOSPRAY NOZZLES

#### GENERAL DESCRIPTION

The Type D3 Protectospray Nozzles are open (non-automatic) directional spray nozzles and they are designed for use in water spray fixed systems for fire protection applications. The 1/2 inch NPT Type D3 Nozzles are external deflector type nozzles that discharge a uniformly filled cone of medium velocity water droplets.

They are especially effective in covering exposed vertical, horizontal, curved, and irregular shaped surfaces in a cooling spray to prevent excessive absorption of heat from an external fire and to prevent possible structural damage or spread of fire to the protected equipment. In some applications, depending on water design density requirements, they may also be used for fire control and extinguishment.

The Type D3 Nozzles are available in a wide variety of orifice sizes and spray angles (included angles of discharge) to provide versatility in system design. Dust Plugs, as described in Technical Data Sheet TD850, are available for use in applications where protection is required against insect infestation or the accumulation of debris within the nozzles. Rupture Disc Assemblies, as described in Technical Data Sheet TD871, may be used to retain priming water in ultra high speed, primed water spray deluge systems controlled by a

Model F460 Primac Valve or by a Model F461 Primac-Multimatic Valve.

Information on 1/2 inch NPT Type D3S Nozzles with individual strainers and K-factors of 1.1 to 2.8 (15.8 to 40.3) is given in Technical Data Sheet TD620C.

Refer to Technical Data Sheet TD620B for information on 1 inch NPT Type D3 Large Capacity Protectospray Nozzles with K-factors of 10.7 to 18.1 (154.1 to 260.6) and Technical Data Sheet TD610A for information on automatic Type EA-1 Protectospray Nozzles.

#### APPROVALS AND STANDARDS

The natural finish, chrome plated, nickel plated, and lead coated bronze, as well as the stainless steel Type D3 Protectospray Nozzles are listed by Underwriters Laboratories Inc. and Underwriters Laboratories of Canada. In addition, they are approved by the Factory Mutual Research Corporation and the Scientific Services Laboratory (Australia).

The Type D3 Protectospray Nozzles are also approved by the New York City Board of Standards and Appeals under Calendar Number 334-79-SA.

#### WARNINGS

*The Type D3 Protectospray Nozzles described herein must be installed*

*and maintained in compliance with this document, as well as with the applicable standards of the National Fire Protection Association, in addition to the standards of any other authorities having jurisdiction. Failure to do so may impair the integrity of these devices.*

*The design of individual water spray fixed systems can vary considerably, depending on the characteristics and nature of the hazard, the basic purpose of the spraying system, the configuration of the hazard, and wind/draft conditions. Because of these variations as well as the wide range of available nozzle spray characteristics, the design of water spray fixed systems for fire protection must only be performed by experienced designers who thoroughly understand the limitations as well as capabilities of such systems.*

*The owner is responsible for maintaining their fire protection system and devices in proper operating condition. The installing contractor or manufacturer should be contacted relative to any questions.*

#### TECHNICAL DATA

The Type D3 Protectospray Nozzles are rated for use at a maximum service pressure of 175 psi (12.1 bar). They are available in natural finish bronze,

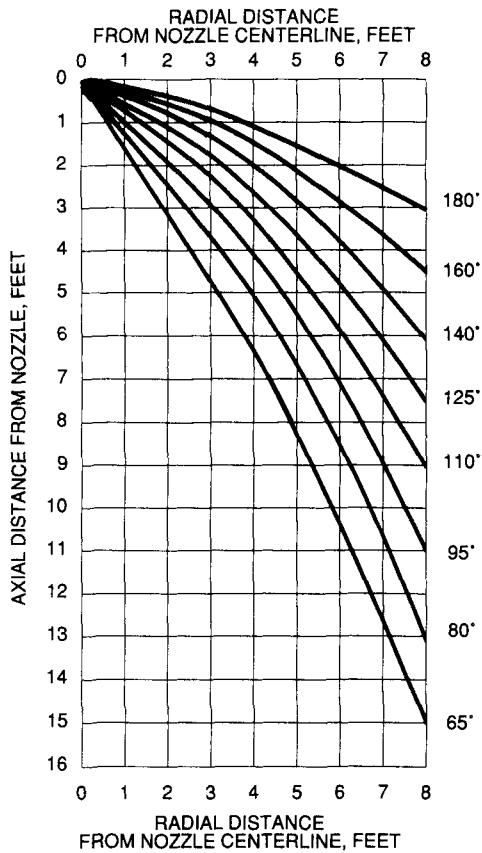

**Design Spray Profiles**  
—Feet and Inches—

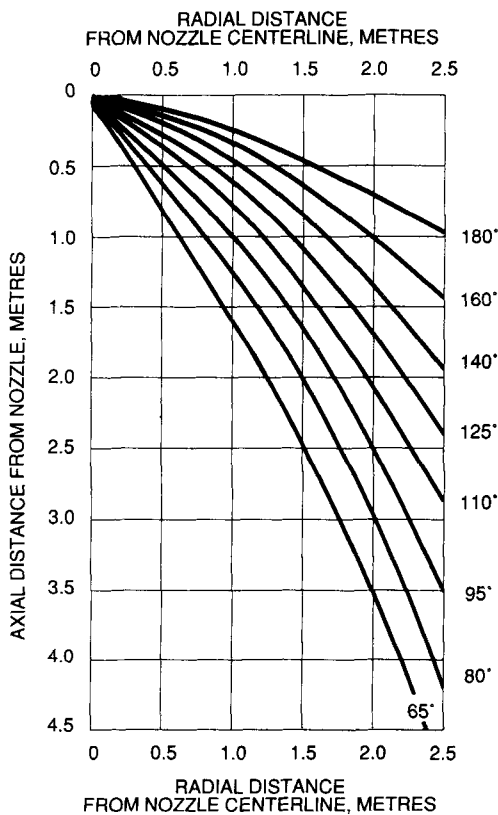

**Design Spray Profiles**  
—Metres—

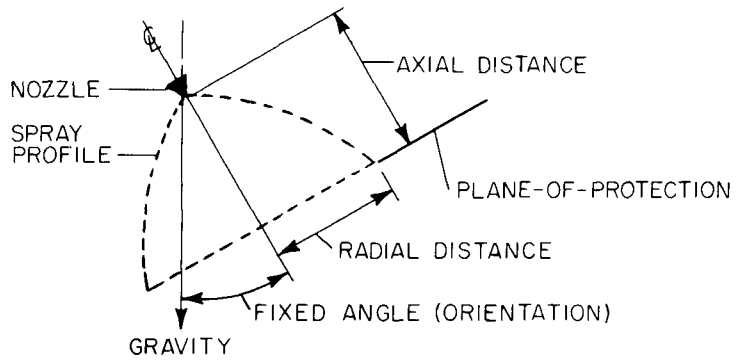

**NOTES:**

1. Design data obtained from tests in still air.
2. Design data applies to a residual (flowing) pressure range at the nozzle inlet of 20 to 60 psi (1.4 to 4.1 bar). For pressures up to 175 psi (12.1 bar) consult the Technical Data Department.  
  
Refer to the authority having jurisdiction for their minimum required residual pressure.
3. The shapes of the Design Spray Profiles remain essentially unchanged over the maximum Axial Distances shown on Pages 3 and 4.
4. For axial distances of 2 feet (0.6 metres) and less and for nozzle spray angles of 65° to 140°, the Design Spray Profile is the same as the nominal spray angle.
5. The maximum Axial Distances shown on Pages 3 and 4 are based on exposure protection.

**FIGURE B**  
**WATER DISTRIBUTION DESIGN DATA**

Orifice Size	Minimum Diameter	K-Factor	
		NFPA (GPM ÷ √psi)	ISO/SI (LPM ÷ √bar)
No. 16	0.203" (5.16mm)	1.2	17.3
No. 18	0.250" (6.35mm)	1.8	25.9
No. 21	0.281" (7.14mm)	2.3	33.1
No. 24	0.328" (8.33mm)	3.0	43.2
No. 28	0.375" (9.53mm)	4.1	59.0
No. 32	0.438" (11.13mm)	5.6	80.6
No. 34	0.500" (12.70mm)	7.2	103.7

**TABLE A**  
**SELECTION OF ORIFICE SIZES**

65°	125°
80°	140°
95°	160°
110°	180°

**TABLE B**  
**SELECTION OF SPRAY ANGLES**

MAXIMUM AXIAL DISTANCE FOR 65° SPRAY ANGLE IN FEET AND INCHES							
FIXED ANGLE	ORIFICE SIZE						
	16	18	21	24	28	32	34
0°	10-6	12-6	13-0	13-3	14-6	15-0	15-6
30°	8-3	10-9	10-9	11-9	12-6	13-6	13-9
45°	7-3	10-0	10-0	11-3	11-6	12-6	12-9
60°	6-6	9-3	9-6	10-9	11-0	11-9	12-6
90°	6-0	8-6	9-0	10-3	10-6	10-9	11-6
120°	5-9	7-6	7-6	7-6	8-3	9-0	9-6
135°	5-6	6-0	6-3	6-6	7-0	8-0	8-6
150°	5-3	5-6	5-6	5-9	6-3	7-3	7-6
180°	5-0	5-0	5-0	5-6	5-9	6-6	7-0

MAXIMUM AXIAL DISTANCE FOR 125° SPRAY ANGLE IN FEET AND INCHES							
FIXED ANGLE	ORIFICE SIZE						
	16	18	21	24	28	32	34
0°	4-6	5-0	6-6	7-9	10-0	10-3	10-6
30°	3-9	3-9	6-3	6-9	8-6	8-6	8-9
45°	3-0	3-6	5-9	6-0	7-9	7-6	8-3
60°	2-6	3-0	5-6	5-9	7-3	7-3	7-9
90°	2-0	2-9	4-9	5-0	5-9	6-0	6-6
120°	1-9	2-3	3-3	3-3	3-9	3-9	4-6
135°	1-6	1-9	2-6	2-6	3-3	3-3	3-9
150°	1-6	1-6	2-0	2-3	2-6	2-9	3-6
180°	1-3	1-3	1-9	2-0	2-3	2-6	3-3

MAXIMUM AXIAL DISTANCE FOR 80° SPRAY ANGLE IN FEET AND INCHES							
FIXED ANGLE	ORIFICE SIZE						
	16	18	21	24	28	32	34
0°	9-0	10-6	11-0	12-0	13-0	14-0	14-0
30°	7-3	8-3	8-9	10-6	11-6	12-3	12-3
45°	6-3	7-6	8-0	10-3	10-6	11-3	11-3
60°	5-6	7-0	7-6	10-0	10-3	10-9	10-9
90°	5-0	6-0	7-0	9-3	9-6	9-9	10-0
120°	4-6	4-9	5-9	6-6	7-3	7-0	8-0
135°	4-3	4-6	5-0	5-6	6-0	6-3	6-9
150°	4-0	4-0	4-6	5-0	5-6	5-6	6-0
180°	3-9	3-9	4-0	4-6	4-9	5-3	5-6

MAXIMUM AXIAL DISTANCE FOR 140° SPRAY ANGLE IN FEET AND INCHES							
FIXED ANGLE	ORIFICE SIZE						
	16	18	21	24	28	32	34
0°	4-0	4-6	6-0	6-6	8-0	8-0	8-0
30°	3-3	3-6	5-6	5-6	6-3	7-0	7-0
45°	2-9	2-9	5-0	5-0	5-6	6-6	6-6
60°	2-3	2-6	4-6	4-6	5-3	5-6	5-9
90°	1-9	2-3	4-0	4-0	4-6	4-6	5-0
120°	1-6	1-9	2-3	2-6	2-6	3-0	3-6
135°	1-3	1-6	1-6	1-9	2-0	2-6	2-9
150°	1-3	1-3	1-6	1-6	1-9	2-3	2-6
180°	1-0	1-0	1-3	1-3	1-6	2-0	2-3

MAXIMUM AXIAL DISTANCE FOR 95° SPRAY ANGLE IN FEET AND INCHES							
FIXED ANGLE	ORIFICE SIZE						
	16	18	21	24	28	32	34
0°	7-0	7-9	9-6	10-6	11-0	12-0	12-6
30°	5-9	6-6	7-9	9-9	10-6	10-9	11-0
45°	5-3	6-3	7-0	9-6	9-9	10-3	10-3
60°	4-9	6-0	6-9	9-3	9-6	9-9	9-9
90°	4-0	5-0	6-6	8-3	8-6	8-9	8-9
120°	3-6	3-9	5-0	5-3	6-3	6-0	6-6
135°	3-3	3-6	4-0	4-6	5-3	5-3	5-6
150°	3-0	3-0	3-6	4-0	4-6	4-6	4-9
180°	3-0	3-0	3-3	3-9	4-0	4-3	4-6

MAXIMUM AXIAL DISTANCE FOR 160° SPRAY ANGLE IN FEET AND INCHES							
FIXED ANGLE	ORIFICE SIZE						
	16	18	21	24	28	32	34
0°	3-6	3-9	4-9	5-0	6-0	6-9	7-0
30°	2-9	3-0	4-3	4-6	5-0	5-9	6-3
45°	2-3	2-6	3-9	4-0	4-6	5-3	5-6
60°	1-9	2-3	3-6	3-9	4-3	4-9	5-3
90°	1-3	1-9	3-0	3-3	3-6	3-9	4-3
120°	1-0	1-3	1-6	2-0	2-0	2-3	2-6
135°	1-0	1-0	1-3	1-3	1-6	1-9	2-0
150°	0-9	0-9	1-0	1-0	1-6	1-6	1-9
180°	0-9	0-9	0-9	0-9	1-3	1-6	1-6

MAXIMUM AXIAL DISTANCE FOR 110° SPRAY ANGLE IN FEET AND INCHES							
FIXED ANGLE	ORIFICE SIZE						
	16	18	21	24	28	32	34
0°	6-0	7-0	9-0	9-6	11-0	11-3	11-6
30°	5-3	6-3	7-3	8-9	9-6	9-9	10-0
45°	4-9	5-9	6-6	8-6	9-0	9-0	9-3
60°	4-3	5-6	6-3	8-3	8-6	8-6	8-9
90°	3-6	4-6	5-9	7-6	7-6	7-6	7-9
120°	2-9	3-3	4-6	4-6	5-6	5-6	5-6
135°	2-6	2-9	3-6	3-6	4-6	4-6	4-9
150°	2-3	2-6	3-0	3-3	3-6	3-9	4-3
180°	2-3	2-3	2-9	3-0	3-3	3-6	3-9

MAXIMUM AXIAL DISTANCE FOR 180° SPRAY ANGLE IN FEET AND INCHES							
FIXED ANGLE	ORIFICE SIZE						
	16	18	21	24	28	32	34
0°	2-9	3-0	3-6	3-6	4-0	6-0	6-0
30°	2-3	2-3	3-6	3-6	3-9	5-0	5-0
45°	1-9	2-0	3-3	3-3	3-6	4-3	4-3
60°	1-6	1-9	2-9	2-9	3-3	3-9	3-9
90°	1-0	1-6	2-0	2-0	2-6	3-0	3-0
120°	0-9	1-0	1-0	1-0	1-6	1-6	1-6
135°	0-6	0-9	0-9	0-9	1-3	1-3	1-3
150°	0-6	0-6	0-6	0-6	1-0	1-0	1-0
180°	0-6	0-6	0-6	0-6	0-9	0-9	0-9

**TABLE C  
MAXIMUM AXIAL DISTANCE BETWEEN  
NOZZLE TIP AND PLANE-OF-PROTECTION FOR EXPOSURE PROTECTION  
—FEET AND INCHES—**

MAXIMUM AXIAL DISTANCE FOR 65° SPRAY ANGLE IN METRES							
FIXED ANGLE	ORIFICE SIZE						
	16	18	21	24	28	32	34
0°	3.2	3.8	4.0	4.0	4.4	4.6	4.7
30°	2.5	3.3	3.3	3.6	3.8	4.1	4.2
45°	2.2	3.0	3.0	3.4	3.5	3.8	3.9
60°	2.0	2.8	2.9	3.3	3.4	3.6	3.8
90°	1.8	2.6	2.7	3.1	3.2	3.3	3.5
120°	1.8	2.3	2.3	2.3	2.5	2.7	2.9
135°	1.7	1.8	1.9	2.0	2.1	2.4	2.6
150°	1.6	1.7	1.7	1.9	1.9	2.2	2.3
180°	1.5	1.5	1.5	1.7	1.8	2.0	2.1

MAXIMUM AXIAL DISTANCE FOR 125° SPRAY ANGLE IN METRES							
FIXED ANGLE	ORIFICE SIZE						
	16	18	21	24	28	32	34
0°	1.4	1.5	2.0	2.4	3.0	3.1	3.2
30°	1.1	1.1	1.9	2.1	2.6	2.6	2.7
45°	0.9	1.1	1.8	1.8	2.4	2.3	2.5
60°	0.8	0.9	1.7	1.8	2.2	2.2	2.4
90°	0.6	0.8	1.4	1.5	1.8	1.8	2.0
120°	0.5	0.7	1.0	1.0	1.1	1.1	1.4
135°	0.5	0.5	0.8	0.8	1.0	1.0	1.1
150°	0.5	0.5	0.6	0.7	0.8	0.8	1.1
180°	0.4	0.4	0.5	0.6	0.7	0.8	1.0

MAXIMUM AXIAL DISTANCE FOR 80° SPRAY ANGLE IN METRES							
FIXED ANGLE	ORIFICE SIZE						
	16	18	21	24	28	32	34
0°	2.7	3.2	3.4	3.7	4.0	4.3	4.3
30°	2.2	2.5	2.7	3.2	3.5	3.7	3.7
45°	1.9	2.3	2.4	3.1	3.2	3.4	3.4
60°	1.7	2.1	2.3	3.0	3.1	3.3	3.3
90°	1.5	1.8	2.1	2.8	2.9	3.0	3.0
120°	1.4	1.4	1.8	2.0	2.2	2.1	2.4
135°	1.3	1.4	1.5	1.7	1.8	1.9	2.1
150°	1.2	1.2	1.4	1.5	1.7	1.7	1.8
180°	1.1	1.1	1.2	1.4	1.4	1.6	1.7

MAXIMUM AXIAL DISTANCE FOR 140° SPRAY ANGLE IN METRES							
FIXED ANGLE	ORIFICE SIZE						
	16	18	21	24	28	32	34
0°	1.2	1.4	1.8	2.0	2.4	2.4	2.4
30°	1.0	1.1	1.7	1.7	1.9	2.1	2.1
45°	0.8	0.8	1.5	1.5	1.7	2.0	2.0
60°	0.7	0.8	1.4	1.4	1.6	1.7	1.8
90°	0.5	0.7	1.2	1.2	1.4	1.4	1.5
120°	0.5	0.5	0.7	0.8	0.8	0.9	1.1
135°	0.4	0.5	0.5	0.5	0.6	0.8	0.8
150°	0.4	0.4	0.5	0.5	0.5	0.7	0.8
180°	0.3	0.3	0.4	0.4	0.5	0.6	0.7

MAXIMUM AXIAL DISTANCE FOR 95° SPRAY ANGLE IN METRES							
FIXED ANGLE	ORIFICE SIZE						
	16	18	21	24	28	32	34
0°	2.1	2.4	2.9	3.2	3.4	3.7	3.8
30°	1.8	2.0	2.4	3.0	3.2	3.3	3.4
45°	1.6	1.9	2.1	2.9	3.0	3.1	3.1
60°	1.4	1.8	2.1	2.8	2.9	3.0	3.0
90°	1.2	1.5	2.0	2.5	2.6	2.7	2.7
120°	1.1	1.1	1.5	1.6	1.9	1.8	2.0
135°	1.0	1.1	1.2	1.4	1.6	1.6	1.7
150°	0.9	0.9	1.1	1.2	1.4	1.4	1.4
180°	0.9	0.9	1.1	1.1	1.2	1.3	1.4

MAXIMUM AXIAL DISTANCE FOR 160° SPRAY ANGLE IN METRES							
FIXED ANGLE	ORIFICE SIZE						
	16	18	21	24	28	32	34
0°	1.1	1.1	1.4	1.5	1.8	2.1	2.1
30°	0.8	0.9	1.3	1.4	1.5	1.8	1.9
45°	0.7	0.8	1.1	1.2	1.4	1.6	1.7
60°	0.5	0.7	1.1	1.1	1.3	1.4	1.6
90°	0.4	0.5	0.9	1.0	1.1	1.1	1.3
120°	0.3	0.4	0.5	0.6	0.6	0.7	0.8
135°	0.3	0.3	0.4	0.4	0.5	0.5	0.6
150°	0.2	0.2	0.3	0.3	0.5	0.5	0.5
180°	0.2	0.2	0.2	0.2	0.4	0.5	0.5

MAXIMUM AXIAL DISTANCE FOR 110° SPRAY ANGLE IN METRES							
FIXED ANGLE	ORIFICE SIZE						
	16	18	21	24	28	32	34
0°	1.8	2.1	2.7	2.9	3.4	3.4	3.5
30°	1.6	1.9	2.2	2.7	2.9	3.0	3.0
45°	1.4	1.8	2.0	2.6	2.7	2.7	2.8
60°	1.3	1.7	1.9	2.5	2.6	2.6	2.7
90°	1.1	1.4	1.8	2.3	2.3	2.3	2.4
120°	0.8	1.0	1.4	1.4	1.7	1.7	1.7
135°	0.8	0.8	1.1	1.1	1.4	1.4	1.4
150°	0.7	0.8	0.9	1.0	1.1	1.1	1.3
180°	0.7	0.7	0.8	0.9	1.0	1.1	1.1

MAXIMUM AXIAL DISTANCE FOR 180° SPRAY ANGLE IN METRES							
FIXED ANGLE	ORIFICE SIZE						
	16	18	21	24	28	32	34
0°	0.8	0.9	1.1	1.1	1.2	1.8	1.8
30°	0.7	0.7	1.1	1.1	1.1	1.5	1.5
45°	0.5	0.6	1.0	1.0	1.1	1.3	1.3
60°	0.5	0.5	0.8	0.8	1.0	1.1	1.1
90°	0.3	0.5	0.6	0.6	0.8	0.9	0.9
120°	0.2	0.3	0.3	0.3	0.5	0.5	0.5
135°	0.2	0.2	0.2	0.2	0.4	0.4	0.4
150°	0.2	0.2	0.2	0.2	0.3	0.3	0.3
180°	0.2	0.2	0.2	0.2	0.2	0.2	0.2

**TABLE D  
MAXIMUM AXIAL DISTANCE BETWEEN  
NOZZLE TIP AND PLANE-OF-PROTECTION FOR EXPOSURE PROTECTION  
—METRES—**

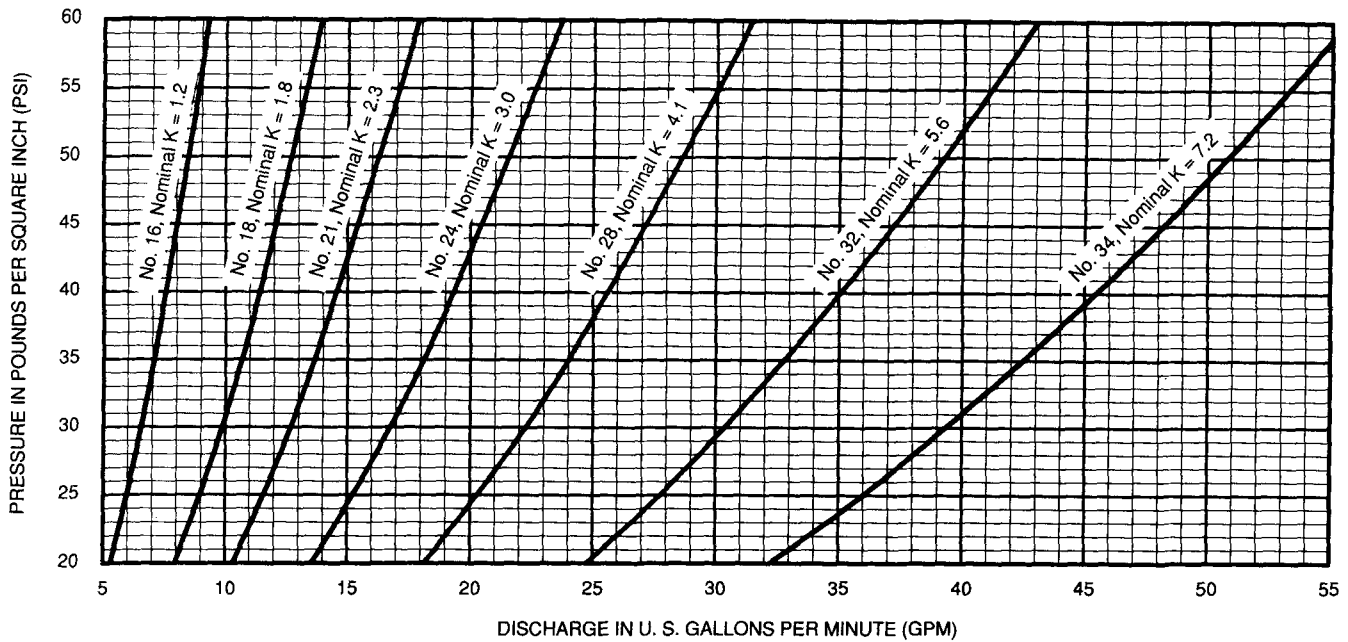

**NOTE:**  $Q = K\sqrt{p}$ ; where "Q" = flow in U.S. gallons per minute, "p" = pressure in pounds per square inch, and "K" is the nominal discharge coefficient.

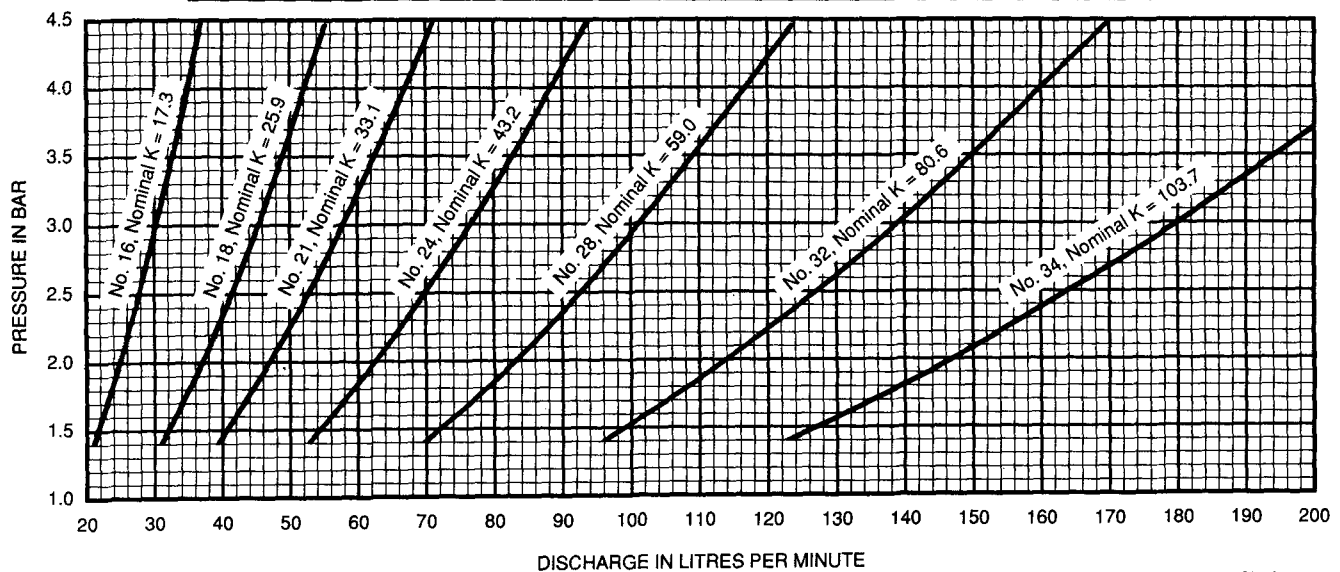

**NOTE:**  $Q = K\sqrt{p}$ ; where "Q" = flow in liters per minute, "p" = pressure in bars, and "K" is the nominal discharge coefficient.

**FIGURE C**  
**NOMINAL DISCHARGE CURVES**  
 (Refer to the authority having jurisdiction for their minimum required residual pressure.)

chrome plated bronze, electroless nickel plated bronze, lead coated bronze, FEP Teflon<sup>®</sup> coated bronze, or natural finish stainless steel.

The frame for the bronze assemblies is silicon bronze per ASTM B584 (C87200) or aluminum bronze per ASTM B148 (C95300), the Deflector is silicon bronze per ASTM B96 (C65500), the Splitter is brass per ASTM B16 (C36000), and the Pin is phosphor bronze.

The Frame for the stainless steel assemblies is stainless steel per ASTM A-296, Grade CF-8M (equivalent to

Type 316). The Deflector, Splitter, and Pin are Type 316 stainless steel.

**Orifice Sizes.** Each orifice size has a numerical designation and the available sizes are as shown in Table A.

The nominal discharge curves and K-factors for the various orifice sizes are given in Figure C.

**Spray Angles.** The nominal spray angles (included angles of discharge) are available as shown in Table B.

**Nozzle Placement.** Where direct impingement of water spray onto all of

the protected surface is required by the authority having jurisdiction, the nozzles are to be spaced and directed so that their spray patterns will completely cover the plane-of-protection with the minimum required average density; however, it is recommended that indoor nozzle spacings be 12 feet (3.7 metres) or less and that outdoor nozzle spacings be 10 feet (3.0 metres) or less. Where rundown or slippage is planned, e.g. exposure protection of vessels per NFPA 15, the preceding recommended indoor and outdoor spacings also apply.

When used for protecting the surfaces

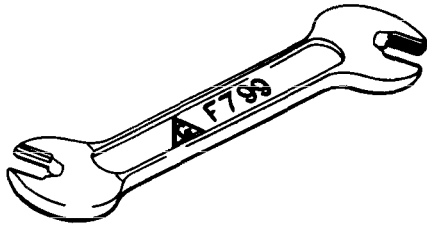

**FIGURE D  
OFFSET SPRINKLER WRENCH**

of a vessel, for example, the nozzles are positioned normal to and approximately 2 feet (0.6 metres) from the surface. This approach, in conjunction with a properly selected spray angle, will tend to make more effective use of the spray as well as help minimize the disturbance effects of wind/draft conditions on the water spray pattern.

**Spray Patterns.** The Design Spray Profiles for the nozzle spray angles of 65° to 180° are as shown in Figure B and apply to discharge pressures of 20 to 60 psi (1.4 to 4.1 bars). Discharge pressures in excess of 60 psi (4.1 bars) will result in a decrease in coverage area since the spray patterns tend to draw inwards at higher pressures. Refer inquiries on higher discharge pressures to the Technical Data Department.

The maximum axial distances between the nozzle tip and plane-of-protection, for exposure protection, are given in Tables C and D. When the axial distance from the nozzle tip to the plane-of-protection is 2 feet (0.6 metres) or less, the Design Spray Profile is the same as the nominal spray angle for spray angles of 65° through 140°.

**NOTES**

Refer to the Warning Section for an important notice concerning the design of individual water spray fixed systems.

Inquiries concerning nozzle installation and usage criteria, not covered by these instructions, should be mailed to the attention of the Technical Data Department. Include sketches and technical details, as appropriate.

**Main Pipeline Strainers.** Main pipeline Strainers are required for systems utilizing nozzles with nominal diameters less than 3/8 inch (9.5mm), i.e. No. 16 thru No. 24 orifice sizes (Ref. Table A), and for any system where the water is likely to contain obstructive material.

**INSTALLATION**

The Type D3 Protectospray Nozzles must be installed using the Model

PSN 49 — 3 X X — X — X X X

ORIFICE SIZE		FINISH & MATERIAL		SPRAY ANGLE	
16	No. 16	1	Natural Finish Bronze	065	65°
18	No. 18	4	Teflon Coated Bronze	085	85°
21	No. 21	5	Electroless Nickel Plated Bronze	095	95°
24	No. 24	7	Lead Coated Bronze	110	110°
28	No. 28	9	Chrome Plated Bronze	125	125°
32	No. 32	0	Natural Finish Stainless Steel	140	140°
34	No. 34			160	160°
				180	180°

**TABLE E  
PRODUCT SYMBOL NUMBER SELECTION**

F799 Offset Sprinkler Wrench shown in Figure D.

**CARE AND MAINTENANCE**

Care must be exercised to avoid damage to the nozzles - both before and after installation. Nozzles damaged by dropping, striking, wrench twist/slippage, or the like, must be replaced.

Water spray fixed systems for fire protection service require regularly scheduled care and maintenance by trained personnel. It is recommended that the Protectospray Nozzles be periodically inspected for loading/obstructions, or other evidence of impaired protection. The inspections should be scheduled weekly or as frequently as may be necessary and, corrective action taken to ensure that the nozzles will perform as intended in the event of a fire.

It is also recommended that outdoor installations of Protectospray Nozzles with Dust Plugs be periodically inspected, during freezing weather conditions, for the presence of ice buildup from trapped condensate which could effect the proper release of the Dust Plugs.

**NOTE**

Before closing a fire protection system main control valve for maintenance work on the fire protection system which it controls, permission to shut

down the affected fire protection system must be obtained from the proper authorities and all personnel who may be affected by this action must be notified.

It is recommended that water spray fixed systems for fire protection be inspected by a qualified Inspection Service.

**WARRANTY**

Seller warrants for a period of one year from the date of shipment (warranty period) that the products furnished hereunder will be free from defects in material and workmanship.

For further details on Warranty, see Price List.

**ORDERING PROCEDURE**

**Protectospray Nozzles:**  
Specify: No. (specify number) orifice, Type D3 Protectospray Nozzle in (specify finish/coating and material) with (specify number) degree spray angle, PSN (specify from Table E).

Contact your local distributor for availability.

**Order Separately:**  
Specify: Model F799 Offset Sprinkler Wrench, PSN 56-452-1-001.